

# DATA SHEET



## **TDA9875** Digital TV Sound Processor (DTVSP)

Preliminary specification  
Supersedes data of 1997 Mar 20  
File under Integrated Circuits, IC02

1998 Feb 13

---

**Digital TV Sound Processor (DTVSP)****TDA9875**

---

**CONTENTS**

1	FEATURES
1.1	Demodulator and decoder section
1.2	DSP section
1.3	Analog audio section
2	GENERAL DESCRIPTION
2.1	Supported standards
3	ORDERING INFORMATION
4	BLOCK DIAGRAM
5	PINNING
6	FUNCTIONAL DESCRIPTION
6.1	Description of the demodulator and decoder section
6.2	Description of the DSP
6.3	Description of the analog audio section
7	LIMITING VALUES
8	THERMAL CHARACTERISTICS
9	CHARACTERISTICS
10	I <sup>2</sup> C-BUS CONTROL
10.1	Introduction
10.2	Power-up state
10.3	Slave receiver mode
10.4	Slave transmitter mode
10.5	Expert mode
11	I <sup>2</sup> S-BUS DESCRIPTION
12	EXTERNAL COMPONENTS
13	PACKAGE OUTLINE
14	SOLDERING
14.1	Introduction
14.2	Soldering by dipping or by wave
14.3	Repairing soldered joints
15	DEFINITIONS
16	LIFE SUPPORT APPLICATIONS
17	PURCHASE OF PHILIPS I <sup>2</sup> C COMPONENTS

# Digital TV Sound Processor (DTVSP)

TDA9875

## 1 FEATURES

### 1.1 Demodulator and decoder section

- Sound IF (SIF) input switch e.g. to select between terrestrial TV SIF and SAT SIF sources
- SIF AGC with 21 dB control range
- SIF 8-bit Analog-to-Digital Converter (ADC)
- DQPSK demodulation for different standards, simultaneously with 1-channel FM demodulation
- NICAM decoding (B/G, I and L standard)
- Two-carrier multistandard FM demodulation (B/G, D/K and M standard)
- Decoding for three analog multi-channel systems (A2, A2+ and A2\*) and satellite sound
- Optional AM demodulation for system L, simultaneously with NICAM
- Programmable identification (B/G, D/K and M standard) and different identification times.

### 1.2 DSP section

- Digital crossbar switch for all digital signal sources and destinations
- Control of volume, balance, contour, bass, treble, pseudo stereo, spatial, bass boost and soft-mute
- Plop-free volume control
- Automatic Volume Level (AVL) control
- Adaptive de-emphasis for satellite
- Programmable beeper
- Monitor selection for FM/AM DC values and signals, with peak detection option
- I<sup>2</sup>S-bus interface for a feature extension (e.g. Dolby surround) with matrix, level adjust and mute.

### 1.3 Analog audio section

- Analog crossbar switch with inputs for mono and stereo (also applicable as SCART 3 input), SCART 1 input/output, SCART 2 input/output and line output
- User defined full-level/-3 dB scaling for SCART outputs
- Output selection of mono, stereo, dual A/B, dual A or dual B
- 20 kHz bandwidth for SCART-to-SCART copies



- Standby mode with functionality for SCART copies
- Dual audio digital-to-analog converter from DSP to analog crossbar switch, bandwidth 15 kHz
- Dual audio ADC from analog inputs to DSP
- Two dual audio Digital-to-Analog Converters (DACs) for loudspeaker (Main) and headphone (Auxiliary) outputs; also applicable for L, R, C and S in the Dolby Pro Logic mode with feature extension.

## 2 GENERAL DESCRIPTION

The TDA9875 is a single-chip Digital TV Sound Processor (DTVSP) for analog and digital multi-channel sound systems in TV sets and satellite receivers.

### 2.1 Supported standards

The multistandard/multi-stereo capability of the TDA9875 is mainly of interest in Europe, but also in Hong Kong/Peoples Republic of China and South East Asia. This includes B/G, D/K, I, M and L standard. In other application areas there exists only subsets of those standard combinations otherwise only single standards are transmitted.

M standard is transmitted in Europe by the American Forces Network (AFN) with European channel spacing (7 MHz VHF, 8 MHz UHF) and monaural sound.

The AM sound of L/L' standard is normally demodulated in the 1st sound IF. The resulting AF signal has to be entered into the mono audio input of the TDA9875. A second possibility is to use the internal AM demodulator stage, however this gives limited performance.

Korea has a stereo sound system similar to Europe and is supported by the TDA9875. Differences include deviation, modulation contents and identification. It is based on M standard.

An overview of the supported standards and sound systems and their key parameters is given in Table 1.

## Digital TV Sound Processor (DTVSP)

TDA9875

## 2.1.1 ANALOG 2-CARRIER SYSTEMS

**Table 1** Frequency modulation

STANDARD	SOUND SYSTEM	CARRIER FREQUENCY (MHz)	FM DEVIATION (kHz) NOM./MAX./OVER	MODULATION		BANDWIDTH/ DE-EMPHASIS (kHz/ $\mu$ s)
				SC1	SC2	
M	mono	4.5	15/25/50	mono	–	15/75
M	A2+	4.5/4.724	15/25/50	$\frac{1}{2}(L + R)$	$\frac{1}{2}(L - R)$	15/75 (Korea)
B/G	A2	5.5/5.742	27/50/80	$\frac{1}{2}(L + R)$	R	15/50
I	mono	6.0	27/50/80	mono	–	15/50
D/K	A2	6.5/6.742	27/50/80	$\frac{1}{2}(L + R)$	R	15/50
D/K	A2*	6.5/6.26	27/50/80	$\frac{1}{2}(L + R)$	R	15/50

**Table 2** Identification for A2 systems

PARAMETER	A2/A2*	A2+ (KOREA)
Pilot frequency	54.6875 kHz = $3.5 \times$ line frequency	55.0699 kHz = $3.5 \times$ line frequency
Stereo identification frequency	117.5 Hz = $\frac{\text{pilot frequency}}{133}$	149.9 Hz = $\frac{\text{pilot frequency}}{105}$
Dual identification frequency	274.1 Hz = $\frac{\text{pilot frequency}}{57}$	276.0 Hz = $\frac{\text{pilot frequency}}{57}$
AM modulation depth	50%	50%

## 2.1.2 2-CARRIER SYSTEMS WITH NICAM

**Table 3** NICAM

STANDARD	SC1				SC2 (MHz) NICAM	DE-EMPHASIS	ROLL-OFF (%)	NICAM CODING
	FREQUENCY (MHz)	TYPE	MODULATION					
			INDEX (%) NOM/MAX.	DEVIATION (kHz) NOM/MAX.				
B/G	5.5	FM	–	27/50	5.85	J17	40	note 1
I	6.0	FM	–	27/50	6.552	J17	100	note 1
D/K	6.5	FM	–	27/50	5.85	J17	40	not yet defined
L	6.5	AM	54/100	–	5.85	J17	40	note 1

**Note**

1. See "EBU specification" or equivalent specification.

## Digital TV Sound Processor (DTVSP)

TDA9875

## 2.1.3 SATELLITE SYSTEMS

An important specification for satellite TV reception is the "Astra specification". The TDA9875 is suited for the reception of Astra and other satellite signals.

**Table 4** FM satellite sound

CARRIER TYPE	CARRIER FREQUENCY (MHz)	MODULATION INDEX	MAXIMUM FM DEVIATION (kHz)	MODULATION	BANDWIDTH/ DE-EMPHASIS (kHz/ $\mu$ s)
Main	6.50 <sup>(1)</sup>	0.26	85	mono	15/50 <sup>(1)</sup>
Sub	7.02/7.20	0.15	50	m/st/d <sup>(2)</sup>	15/adaptive <sup>(3)</sup>
Sub	7.38/7.56	0.15	50	m/st/d <sup>(2)</sup>	15/adaptive <sup>(3)</sup>
Sub	7.74/7.92	0.15	50	m/st/d <sup>(2)</sup>	15/adaptive <sup>(3)</sup>
Sub	8.10/8.28	0.15	50	m/st/d <sup>(2)</sup>	15/adaptive <sup>(3)</sup>

**Notes**

1. For other satellite systems, frequencies of, for example, 5.80, 6.60 or 6.65 MHz can also be received. A de-emphasis of 60  $\mu$ s, or in accordance with J17, is available.
2. m/st/d = mono or stereo or dual language sound.
3. Adaptive de-emphasis = compatible to transmitter specification.

**3 ORDERING INFORMATION**

TYPE NUMBER	PACKAGE		
	NAME	DESCRIPTION	VERSION
TDA9875	SDIP64	plastic shrink dual in-line package; 64 leads (750 mil)	SOT274-1

# Digital TV Sound Processor (DTVSP)

# TDA9875

## 4 BLOCK DIAGRAM

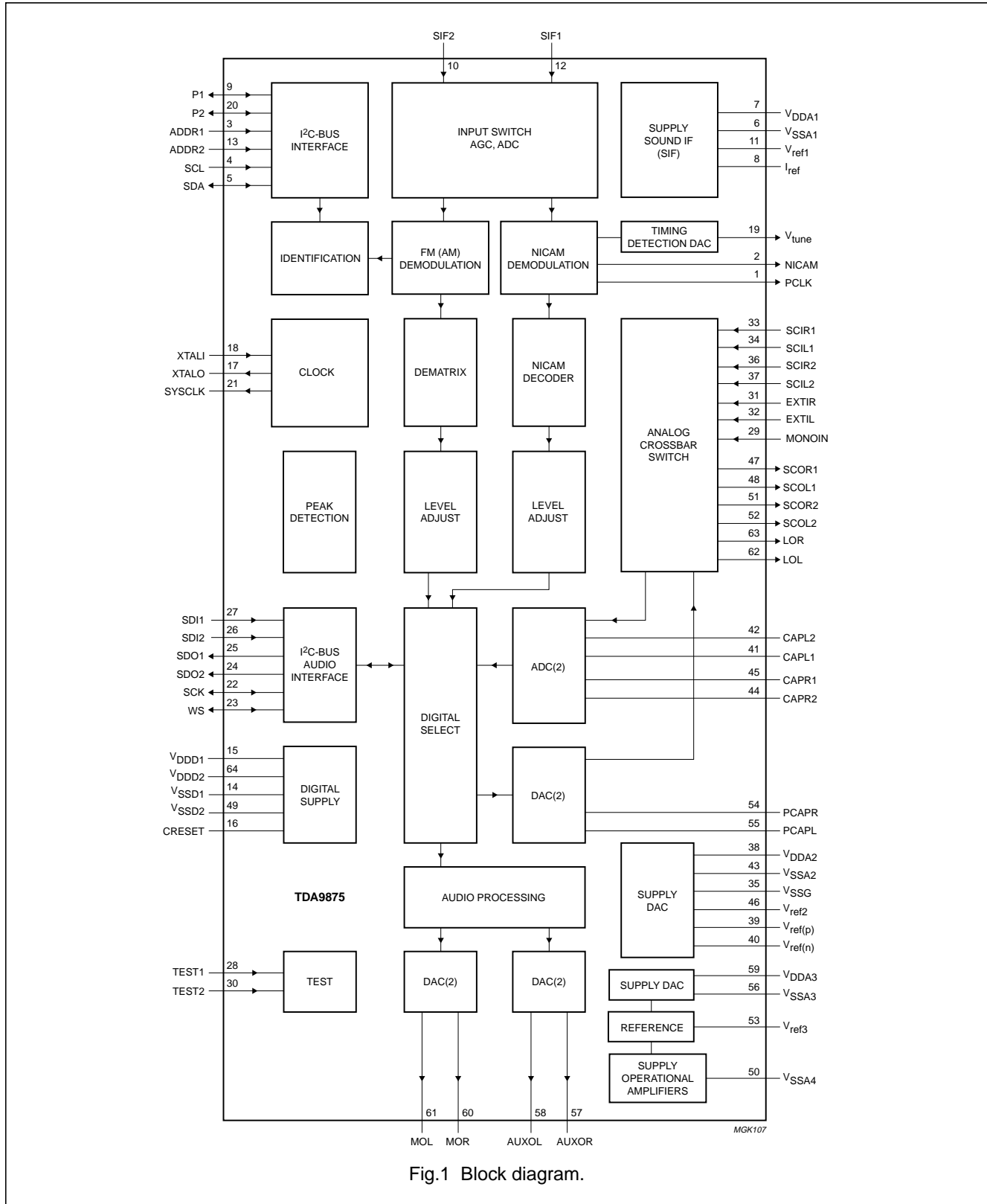

Fig.1 Block diagram.

## Digital TV Sound Processor (DTVSP)

TDA9875

## 5 PINNING

SYMBOL	PIN	I/O	DESCRIPTION
PCLK	1	O	NICAM clock output at 728 kHz
NICAM	2	O	serial NICAM data output at 728 kHz
ADDR1	3	I	first I <sup>2</sup> C-bus slave address modifier
SCL	4	I	I <sup>2</sup> C-bus clock
SDA	5	I/O	I <sup>2</sup> C-bus data
V <sub>SSA1</sub>	6	supply	supply ground 1; analog front-end circuitry
V <sub>DDA1</sub>	7	supply	analog supply voltage 1; analog front-end circuitry
I <sub>ref</sub>	8	–	resistor for reference current generator; analog front-end circuitry
P1	9	I/O	first general purpose I/O pin
SIF2	10	I	sound IF input 2
V <sub>ref1</sub>	11	–	reference voltage; analog front-end circuitry
SIF1	12	I	sound IF input 1
ADDR2	13	I	second I <sup>2</sup> C-bus slave address modifier
V <sub>SSD1</sub>	14	supply	supply ground 1; digital circuitry
V <sub>DDD1</sub>	15	supply	digital supply voltage 1; digital circuitry
CRESET	16	–	capacitor for power-on reset
XTALO	17	O	crystal oscillator output
XTALI	18	I	crystal oscillator input
V <sub>tune</sub>	19	O	tuning voltage output for crystal oscillator
P2	20	I/O	second general purpose I/O pin
SYSCCLK	21	O	system clock output
SCK	22	I/O	I <sup>2</sup> S-bus clock
WS	23	I/O	I <sup>2</sup> S-bus word select
SDO2	24	O	I <sup>2</sup> S-bus data output 2
SDO1	25	O	I <sup>2</sup> S-bus data output 1
SDI2	26	I	I <sup>2</sup> S-bus data input 2
SDI1	27	I	I <sup>2</sup> S-bus data input 1
TEST1	28	I	first test pin; connected to V <sub>SSD1</sub> for normal operation
MONOIN	29	I	audio mono input
TEST2	30	I	second test pin; connected to V <sub>SSD1</sub> for normal operation
EXTIR	31	I	external audio input right channel
EXTIL	32	I	external audio input left channel
SCIR1	33	I	SCART 1 input right channel
SCIL1	34	I	SCART 1 input left channel
V <sub>SSG</sub>	35	–	ground guards; audio analog-to-digital converter circuitry
SCIR2	36	I	SCART 2 input right channel
SCIL2	37	I	SCART 2 input left channel
V <sub>DDA2</sub>	38	supply	analog supply voltage 2; audio analog-to-digital converter circuitry
V <sub>ref(p)</sub>	39	–	positive reference voltage; audio analog-to-digital converter circuitry
V <sub>ref(n)</sub>	40	–	reference voltage ground; audio analog-to-digital converter circuitry

## Digital TV Sound Processor (DTVSP)

## TDA9875

SYMBOL	PIN	I/O	DESCRIPTION
CAPL1	41	–	filter capacitor pin 1; audio analog-to-digital converter, left channel
CAPL2	42	–	filter capacitor pin 2; audio analog-to-digital converter, left channel
V <sub>SSA2</sub>	43	supply	supply ground 2; audio analog-to-digital converter circuitry
CAPR2	44	–	filter capacitor pin 2; audio analog-to-digital converter, right channel
CAPR1	45	–	filter capacitor pin 1; audio analog-to-digital converter, right channel
V <sub>ref2</sub>	46	–	reference voltage; audio analog-to-digital converter circuitry
SCOR1	47	O	SCART 1 output right channel
SCOL1	48	O	SCART 1 output left channel
V <sub>SSD2</sub>	49	supply	supply ground 2; digital circuitry
V <sub>SSA4</sub>	50	supply	supply ground 4; audio operational amplifier circuitry
SCOR2	51	O	SCART 2 output right channel
SCOL2	52	O	SCART 2 output left channel
V <sub>ref3</sub>	53	–	reference voltage; audio digital-to-analog converter and operational amplifier circuitry
PCAPR	54	–	post-filter capacitor pin right channel, audio digital-to-analog converter
PCAPL	55	–	post-filter capacitor pin left channel, audio digital-to-analog converter
V <sub>SSA3</sub>	56	supply	supply ground 3; audio digital-to-analog converter circuitry
AUXOR	57	O	headphone (Auxiliary) output right channel
AUXOL	58	O	headphone (Auxiliary) output left channel
V <sub>DDA3</sub>	59	supply	analog supply voltage 3; audio digital-to-analog converter
MOR	60	O	loudspeaker (Main) output right channel
MOL	61	O	loudspeaker (Main) output left channel
LOL	62	O	line output left channel
LOR	63	O	line output right channel
V <sub>DD2</sub>	64	supply	digital supply voltage 2; digital circuitry



Digital TV Sound Processor (DTVSP)

TDA9875

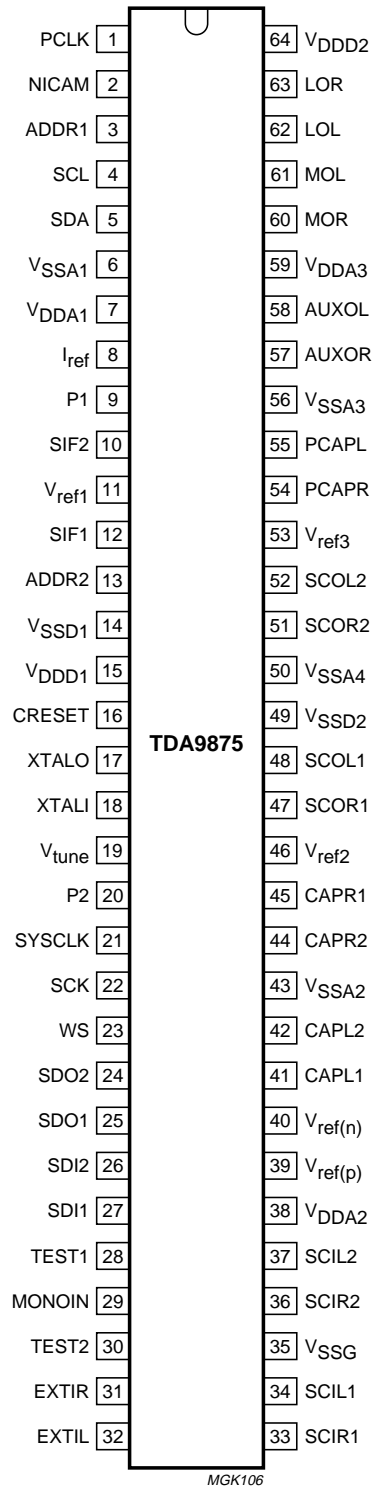

Fig.2 Pin configuration.

## Digital TV Sound Processor (DTVSP)

## TDA9875

**6 FUNCTIONAL DESCRIPTION****6.1 Description of the demodulator and decoder section****6.1.1 SIF INPUT**

Two input pins are provided, SIF1 e.g. for terrestrial TV and SIF2 e.g. for a satellite tuner. As no specific filters are integrated, both inputs have the same specification giving flexibility in application. The selected signal is passed through an AGC circuit and then digitized by an 8-bit ADC operating at 24.576 MHz.

**6.1.2 AGC**

The gain of the AGC amplifier is controlled from the ADC output by means of a digital control loop employing hysteresis. The AGC has a fast attack behaviour to prevent ADC overloads and a slow decay behaviour to prevent AGC oscillations. For AM demodulation the AGC must be switched off. When switched off, the control loop is reset and fixed gain settings can be chosen from Table 12 (subaddress 0).

The AGC can be controlled via the I<sup>2</sup>C-bus. Details can be found in the I<sup>2</sup>C-bus register definitions (see Chapter 10).

**6.1.3 MIXER**

The digitized input signal is fed to the mixers, which mix one or both input sound carriers down to zero IF. A 24-bit control word for each carrier sets the required frequency. Access to the mixer control word registers is via the I<sup>2</sup>C-bus. When receiving NICAM programs, a feedback signal is added to the control word of the second carrier mixer to establish a carrier-frequency loop.

**6.1.4 FM AND AM DEMODULATION**

An FM or AM input signal is fed via a band-limiting filter to a demodulator that can be used for either FM or AM demodulation. Apart from the standard (fixed) de-emphasis characteristic, an adaptive de-emphasis is available for encoded satellite programs. A stereo decoder recovers the left and right signal channels from the demodulated sound carriers. Both the European and Korean stereo systems are supported.

**6.1.5 FM IDENTIFICATION**

The identification of the FM sound mode is performed by AM synchronous demodulation of the pilot signal and narrow-band detection of the identification frequencies. The result is available via the I<sup>2</sup>C-bus interface. A selection can be made via the I<sup>2</sup>C-bus for B/G, D/K and M standard and for three different modes that represent different trade-offs between speed and reliability of identification.

**6.1.6 NICAM DEMODULATION**

The NICAM signal is transmitted in a DQPSK code at a bit rate of 728 kbit/s. The NICAM demodulator performs DQPSK demodulation and feeds the resulting bitstream and clock signal onto the NICAM decoder and, for evaluation purposes, to PCLK (pin 1) and NICAM (pin 2).

A timing loop controls the frequency of the crystal oscillator to lock the sampling rate to the symbol timing of the NICAM data. The polarity of the control signal is selectable to support applications in which external circuitry is used to boost the tuning voltage of the oscillator.

**6.1.7 NICAM DECODER**

The device performs all decoding functions in accordance with the "EBU NICAM 728 specification". After locking to the frame alignment word, the data is descrambled by applying the defined pseudo-random binary sequence; the device will then synchronize to the periodic frame flag bit C0.

The status of the NICAM decoder can be read out from the NICAM status register by the user (see the I<sup>2</sup>C-bus register description in Section 10.4.2). The OSB bit indicates that the decoder has locked to the NICAM data. The VDSP bit indicates that the decoder has locked to the NICAM data and that the data is valid sound data. The C4 bit indicates that the sound conveyed by the FM mono channel is identical to the sound conveyed by the NICAM channel. The error byte contains the number of sound sample errors, resulting from parity checking, that occurred in the past 128 ms period. The Bit Error Rate (BER) can be calculated using the following equation;

$$\text{BER} = \frac{\text{bit errors}}{\text{total bits}} \approx \text{error byte} \times 1.74 \times 10^{-5}$$

---

## Digital TV Sound Processor (DTVSP)

## TDA9875

---

### 6.1.8 NICAM AUTO-MUTE

This function is enabled by setting bit AMUTE LOW subaddress 14 (see Section 10.3.11). Upper and lower error limits may be defined by writing appropriate values to two registers in the I<sup>2</sup>C-bus section (subaddresses 16 and 17; see Sections 10.3.13 and 10.3.14). When the number of errors in a 128 ms period exceeds the upper error limit the auto-mute function will switch the output sound from NICAM to whatever sound is on the first sound carrier (FM or AM). When the error count is smaller than the lower error limit the NICAM sound is restored.

The auto-mute function can be disabled by setting bit AMUTE HIGH. In this condition clicks become audible when the error count increases; the user will hear a signal of degrading quality.

A decision to enable/disable the auto-muting is taken by the microcontroller based on an interpretation of the application control bits C1, C2, C3 and C4 and, possibly, any additional strategy implemented by the set maker in the microcontroller software.

When the AM sound in NICAM L systems is demodulated in the 1st sound IF and the audio signal connected to the mono input of the TDA9875, the controlling microcontroller must implement the switching from NICAM reception to mono input, if auto-muting is desired.

### 6.1.9 CRYSTAL OSCILLATOR

A circuit diagram of the external components of the voltage-controlled crystal oscillator is illustrated in Fig.8 (see Chapter 12).

### 6.1.10 TEST PINS

Both test pins are active HIGH, in normal operation of the device they are wired to  $V_{SSD1}$ . Test functions are for manufacturing tests only and are not available to customers. Without external circuitry these pads are pulled down to LOW level with internal resistors.

# Digital TV Sound Processor (DTVSP)

TDA9875

## 6.2 Description of the DSP

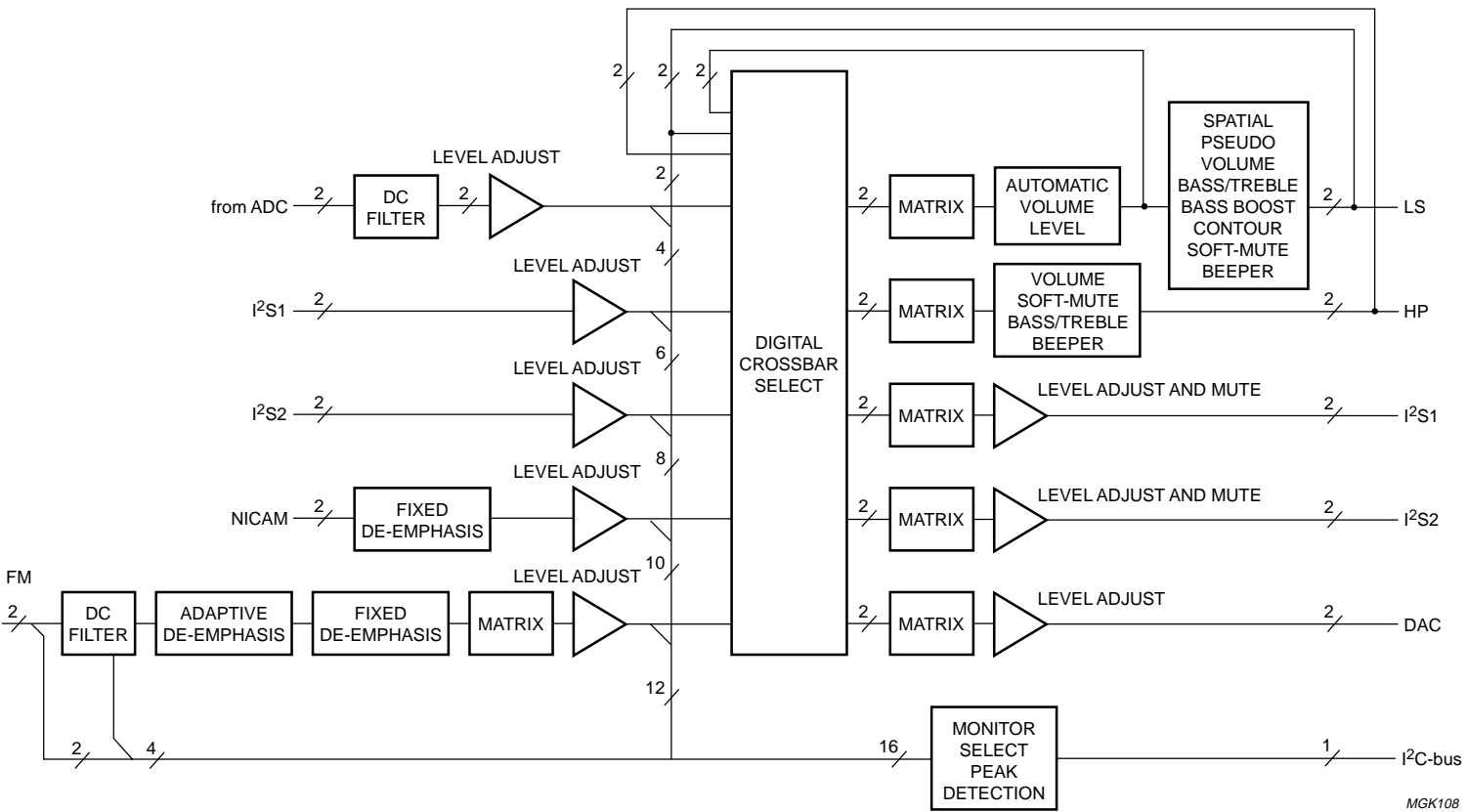

Fig.3 DSP data flow diagram.

## Digital TV Sound Processor (DTVSP)

## TDA9875

### 6.2.1 LEVEL SCALING

All input channels to the digital crossbar switch (except for the loudspeaker feedback path) are equipped with a level adjust facility to change the signal level in a range of  $\pm 15$  dB. It is recommended to scale all input channels to be 15 dB below full-scale ( $-15$  dB full-scale) under nominal conditions.

### 6.2.2 NICAM PATH

The NICAM path has a switchable J17 de-emphasis.

### 6.2.3 FM (AM) PATH

A high-pass filter suppresses DC offsets from the FM demodulator due to carrier frequency offsets and supplies the monitor/peak function with DC values and an unfiltered signal, e.g. for the purpose of carrier detection.

The de-emphasis function offers fixed settings for the supported standards (50  $\mu$ s, 60  $\mu$ s, 75  $\mu$ s and J17).

An adaptive de-emphasis is available for Wegener-Panda 1 encoded programs.

A matrix performs the dematrixing of  $\frac{1}{2}(L + R)$  and R to L and R signals, of  $\frac{1}{2}(L + R)$  and  $\frac{1}{2}(L - R)$  to L and R signals or of channel 1 and channel 2 to L and R signals.

### 6.2.4 NICAM AUTO-MUTE

If NICAM is received and the signal quality becomes poor, the digital crossbar switch switches automatically to FM and switches the matrix to channel 1. The automatic switching between NICAM and channel 1 (FM or AM) reception depends on the NICAM bit error rate. The auto-mute function can be disabled via the I<sup>2</sup>C-bus.

### 6.2.5 MONITOR

This function provides data words from a number of locations of the signal processing paths to the I<sup>2</sup>C-bus interface (2 data bytes). Signal sources include the FM demodulator outputs, most inputs to the digital crossbar switch and the inputs to the loudspeaker channel of the ADC. Source selection and data read-out is performed via the I<sup>2</sup>C-bus.

Optionally, the peak value can be measured instead of simply taking samples. The internally stored peak value is reset to zero when the data is read via the I<sup>2</sup>C-bus. The monitor function may be used, for example, for signal level measurements or carrier detection.

### 6.2.6 LOUDSPEAKER (MAIN) CHANNEL

The matrix provides the following functions; forced mono, stereo, channel swap, channel 1, channel 2 and spatial effects.

There are fixed coefficient sets for spatial settings of 30%, 40% and 52%.

The Automatic Volume Level (AVL) function provides a constant output level of  $-23$  dB full-scale for input levels between 0 dBFS and  $-29$  dB full-scale. There are some fixed decay time constants to choose from, i.e. 2, 4 and 8 seconds.

Pseudo stereo is based on a phase shift in one channel via a 2nd-order all-pass filter. There are fixed coefficient sets to provide 90 degrees phase shift at frequencies of 150, 200 and 300 Hz.

Volume is controlled individually for each channel ranging from  $+24$  dB to  $-83$  dB with 1 dB resolution. There is also a mute position. For the purpose of a simple control software in the microcontroller, the decimal number that is sent as an I<sup>2</sup>C-bus data byte for volume control is identical to the volume setting in dBs (e.g. the I<sup>2</sup>C-bus data byte  $+10$  sets the new volume value to  $+10$  dB).

Balance can be realized by independent control of the left and right channel volume settings.

Contour is adjustable between 0 dB and  $+18$  dB with 1 dB resolution.

Bass is adjustable between  $+15$  dB and  $-12$  dB with 1 dB resolution and treble is adjustable between  $\pm 12$  dB with 1 dB resolution.

For the purpose of a simple control software in the microcontroller, the decimal number that is sent as an I<sup>2</sup>C-bus data byte for contour, bass or treble is identical to the new contour, bass or treble setting in dBs (e.g. the I<sup>2</sup>C-bus data byte  $+8$  sets the new value to  $+8$  dB).

Extra bass boost is provided up to 20 dB with 2 dB resolution. The implemented coefficient set serves merely as an example on how to use this filter.

The beeper provides tones in a range from approximately 400 Hz to 30 kHz. The frequency can be selected via the I<sup>2</sup>C-bus. The beeper output signal is added to the loudspeaker and headphone channel signals. The beeper volume is adjustable with respect to full-scale between 0 dB and  $-93$  dB with a 3 dB step resolution. The beeper is not effected by mute.

## Digital TV Sound Processor (DTVSP)

## TDA9875

Soft-mute provides a mute ability in addition to volume control with a well defined time (32 ms) after which the soft-mute is completed. A smooth fading is achieved by a cosine masking.

### 6.2.7 HEADPHONE (AUXILIARY) CHANNEL

The matrix provides the following functions; forced mono, stereo, channel swap, channel 1 and channel 2 (or C and S in Dolby Surround Pro Logic mode).

Volume is controlled individually for each channel in a range from +24 to -83 dB with 1 dB resolution. There is also a mute position. For the purpose of a simple control software in the microcontroller, the decimal number that is sent as an I<sup>2</sup>C-bus data byte for volume control is identical to the volume setting in dBs (e.g. the I<sup>2</sup>C-bus data byte +10 sets the new volume value to +10 dB).

Balance can be realized by independent control of the left and right channel volume settings.

Bass is adjustable between +15 dB and -12 dB with 1 dB resolution and treble is adjustable between ±12 dB with 1 dB resolution.

For the purpose of a simple control software in the microcontroller, the decimal number that is sent as an I<sup>2</sup>C-bus data byte for bass or treble is identical to the new bass or treble setting in dB (e.g. the I<sup>2</sup>C-bus data byte +8 sets the new value to +8 dB).

The beeper provides tones in a range from approximately 400 Hz to 30 kHz. The frequency can be selected via the I<sup>2</sup>C-bus. The beeper output signal is added to the loudspeaker and headphone channel signals. The beeper volume is adjustable with respect to full-scale between 0 dB and -93 dB with a 3 dB step resolution. The beeper is not effected by mute.

Soft-mute provides a mute ability in addition to volume control with a well defined time (32 ms) after which the soft-mute is completed. A smooth fading is achieved by a cosine masking.

### 6.2.8 FEATURE INTERFACE

The feature interface comprises two I<sup>2</sup>S-bus input/output ports and a system clock output. Each I<sup>2</sup>S-bus port is equipped with level adjust facilities that can change the signal level in a ±15 dB range in 1 dB steps. Outputs can be disabled to improve EMC performance.

The I<sup>2</sup>S-bus output matrix provides the following functions; forced mono, stereo, channel swap, channel 1 and channel 2.

One example of how the feature interface can be used in a TV set is to connect an external Dolby Surround Pro Logic DSP, such as the SAA7710, to the I<sup>2</sup>S-bus ports. Outputs must be enabled and a suitable master clock signal for the DSP can be taken from pin SYSCLK.

A stereo signal from any source will be output on one of the I<sup>2</sup>S-bus serial data outputs and the four processed signal channels will be entered at both I<sup>2</sup>S-bus serial data inputs. Left and right could then be output to the power amplifiers via the Main channel, centre and surround via the Auxiliary channel.

### 6.2.9 CHANNEL FROM THE AUDIO ANALOG-TO-DIGITAL CONVERTER

The signal level at the output of the ADC can be adjusted in a range of ±15 dB with a 1 dB step resolution. The audio ADC itself is scaled to a gain of -6 dB.

### 6.2.10 CHANNEL TO THE ANALOG CROSSBAR PATH

Level adjust with control positions 0 dB, +3 dB, +6 dB and +9 dB.

### 6.2.11 DIGITAL CROSSBAR SWITCH (SEE Fig.6)

Input channels to the crossbar switch are from the audio ADC, I<sup>2</sup>S1, I<sup>2</sup>S2, FM path, NICAM path and from the loudspeaker channel path after matrix and AVL.

Output channels comprise loudspeaker, headphone, I<sup>2</sup>S1, I<sup>2</sup>S2 and the audio DACs for line output and SCART.

The I<sup>2</sup>S1 and I<sup>2</sup>S2 outputs also provide digital outputs from the loudspeaker and headphone channels, but without the beeper signals.

### 6.2.12 GENERAL

There are a number of functions that can provide signal gain, e.g. volume, bass and treble control. Great care has to be taken when using gain with large input signals in order not to exceed the maximum possible signal swing, which would cause severe signal distortion. The nominal signal level of the various signal sources to the digital crossbar switch should be 15 dB below digital full-scale (-15 dB full-scale). This means that a volume setting of, say, +15 dB would just produce a full-scale output signal and not cause clipping, if the signal level is nominal.

Sending illegal data patterns via the I<sup>2</sup>C-bus will not cause any changes of the current setting for the volume, bass, treble, bass boost and level adjust functions.

## Digital TV Sound Processor (DTVSP)

## TDA9875

## 6.2.13 EXPERT MODE

The TDA9875 provides a special expert mode that gives direct write access to the internal Coefficient RAM (CRAM) of the DSP. It can be used to create user-defined characteristics, such as a tone control with different corner frequencies or special boost/cut characteristics to correct the low-frequency loudspeaker and/or cabinet frequency responses by means of the bass boost filter. However, this mode must be used with great care.

More information on the functions of this device, such as filter structures, the number of coefficients per function, their default values, memory addresses, etc., can be made available on request.

## 6.2.14 DSP CHARACTERISTICS

**Table 5** DSP characteristics

FUNCTION	EXPERT MODE	PARAMETER	VALUE	UNIT
Bass control for loudspeaker and headphone output	yes	control range	-12 to +15	dB
		step resolution	1	dB
		step resolution at frequency	40	Hz
Treble control for loudspeaker and headphone output	yes	control range	-12 to +12	dB
		step resolution	1	dB
		step resolution at frequency	14	kHz
Contour for loudspeaker output	yes	control range	0 to +18	dB
		step resolution	1	dB
		step resolution at frequency	40	Hz
Bass boost for loudspeaker output	yes	control range	0 to +20	dB
		step resolution	2	dB
		step resolution at frequency	20	Hz
		corner frequency	350	Hz
Volume control for each separate channel in loudspeaker and headphone output	no	control range	-83 to +24	dB
		step resolution	1	dB
		mute position at step	10101100	
Soft-mute for loudspeaker and headphone output	no	processing time	32	ms
Spatial effects	yes	anti-phase crosstalk positions	30, 40 and 52	%
Pseudo stereo	yes	90 degree phase shift at frequency	150, 200 and 300	Hz
Beeper additional to the signal in the loudspeaker and headphone channel	yes	beep frequencies	see Section 10.3.38	
		control range	0 to -93	dB
		step resolution	3	dB
		mute position at step	00100000	
AVL	no	step width	quasi continuously	
		AVL output level for an input level between 0 dB and -29 dB (full-scale)	-23	dB
		attack time	10	ms
		decay time constant	2, 4 and 8	s
General	no	-3 dB lower corner frequency of DSP	10	Hz
		-1 dB bandwidth of DSP	14.5	kHz

Digital TV Sound Processor (DTVSP)

TDA9875

FUNCTION	EXPERT MODE	PARAMETER	VALUE	UNIT
Level adjust I <sup>2</sup> S1 and I <sup>2</sup> S2 inputs	yes	control range	-15 to +15	dB
		step resolution	1	dB
Level adjust I <sup>2</sup> S1 and I <sup>2</sup> S2 outputs	yes	control range	-15 to +15	dB
		step resolution	1	dB
		mute position at step	00010000	
Level adjust analog crossbar path	no	control positions	0, 3, 6 and 9	dB
Level adjust audio ADC outputs	yes	control range	+15 to -15	dB
		step resolution	1	dB
Level adjust NICAM path	yes	control range	+15 to -15	dB
		step resolution	1	dB
Level adjust FM path	yes	control range	+15 to -15	dB
		step resolution	1	dB

6.3 Description of the analog audio section

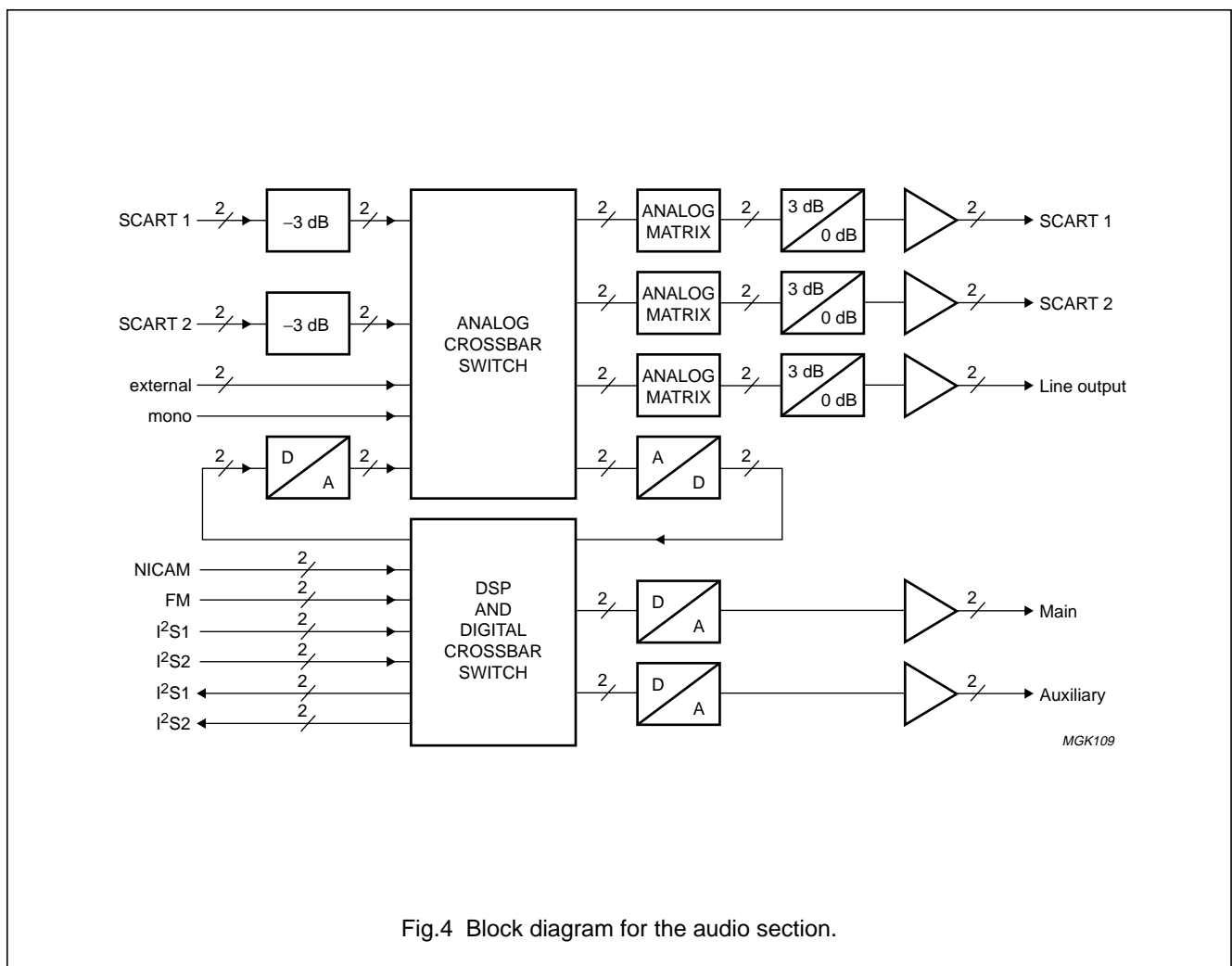

Fig.4 Block diagram for the audio section.



# Digital TV Sound Processor (DTVSP)

# TDA9875

### 6.3.1 ANALOG CROSSBAR SWITCH AND ANALOG MATRIX (see also Fig.6)

There are a number of analog input and output ports with the TDA9875. Analog source selector switches are employed to provide the desired analog signal routing capability. The analog signal routing is performed by the analog crossbar switch section. A dual audio ADC provides the connection to the DSP section and a dual audio DAC provides the connection from the DSP section to the analog crossbar switch. The digital signal routing is performed by a digital crossbar switch.

The basic signal routing philosophy of the TDA9875 is that each switch handles two signal channels at the same time, e.g. left and right, language A and B, directly at the source.

Each source selector switch is followed by an analog matrix to perform further selection tasks, such as putting a signal from one input channel, say language A, to both output channels or for swapping left and right channels. The analog matrix provides the functions given in Table 6 (see also Fig.5).

**Table 6** Analog matrix functions

MODE	MATRIX OUTPUT	
	LEFT OUTPUT	RIGHT OUTPUT
1	left input	right input
2	right input	left input
3	left input	left input
4	right input	right input

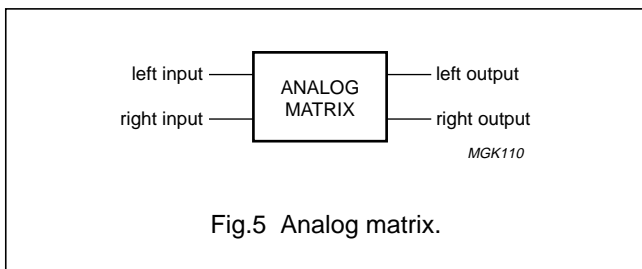

All switches and matrices are controlled via the I<sup>2</sup>C-bus.

There is one restriction for switching signals at inputs and outputs for SCART 1 and SCART 2. At these ports, an input signal cannot be copied to its own output, i.e. it is not possible to make a copy from SCART 1 input to SCART 1 output.

### 6.3.2 SCART INPUTS

The SCART specification allows for a signal level of up to 2 V (RMS). Because of signal handling limitations, due to the 5 V supply voltage of the TDA9875, it is necessary to have fixed 3 dB attenuators at the SCART inputs to obtain a 2 V input. This results in a -3 dB SCART-to-SCART copy gain. If 0 dB copy gain is preferred (with maximum 1.4 V input), there are +3 dB/0 dB amplifiers at the outputs of SCART 1 and SCART 2 and at the line output.

The input attenuator is realized by an external series resistor in combination with the input impedance, both of which form a voltage divider. With this voltage divider the maximum SCART signal level of 2 V (RMS) is scaled down to 1.4 V (RMS) at the input pin. If it is known for certain applications that the input signal level is always below 1.4 V (RMS), the SCART inputs can be used without external resistors.

### 6.3.3 EXTERNAL AND MONO INPUTS

The 3 dB input attenuators are not required for the external and mono inputs, because those signal levels are under control of the TV designer. The maximum allowed input level is 1.4 V (RMS). By adding external series resistors, the external inputs can be used as an additional SCART input.

### 6.3.4 SCART OUTPUTS

The SCART outputs employ amplifiers with two gain settings. The gain can be set to +3 dB or to 0 dB via the I<sup>2</sup>C-bus. The +3 dB position is needed to compensate for the 3 dB attenuation at the SCART inputs should SCART-to-SCART copies with 0 dB gain be preferred [under the condition of 1.4 V (RMS) maximum input level]. The 0 dB position is needed, for example, for an external-to-SCART copy with 0 dB gain.

### 6.3.5 LINE OUTPUT

The line output can provide an unprocessed copy of the audio signal in the loudspeaker channels. This can be either an external signal that comes from the dual audio ADC, or a signal from an internal digital audio source that comes from the dual audio DAC. The line output employs amplifiers with two gain settings. The +3 dB position is needed to compensate for the attenuation at the SCART inputs, while the 0 dB position is needed, for example, for non-attenuated external or internal digital signals (see Section 6.3.4).

---

## Digital TV Sound Processor (DTVSP)

## TDA9875

---

### 6.3.6 LOUDSPEAKER (MAIN) AND HEADPHONE (AUXILIARY) OUTPUTS

Signals from any audio source can be applied to the loudspeaker and to the headphone output channels via the digital crossbar switch and the DSP.

### 6.3.7 DUAL AUDIO DAC

The TDA9875 contains three dual audio DACs, one for the connection from the DSP to the analog crossbar switch section and two for the loudspeaker and headphone outputs. Each of the three dual low-noise high-dynamic range DACs consists of two 15-bit DACs with current outputs, followed by a buffer operational amplifier. The audio DACs operate with four-fold oversampling and noise shaping.

### 6.3.8 DUAL AUDIO ADC

There is one dual audio ADC in the TDA9875 for the connection of the analog crossbar switch section to the DSP. The dual audio ADC consists of two bitstream 3rd-order sigma-delta audio ADCs and a high-order decimation filter.

### 6.3.9 STANDBY MODE

The standby mode (subaddress 1, bit 5) disables most functions and reduces power dissipation. The analog crossbar switch and the SCART section remains operational and can be controlled by the I<sup>2</sup>C-bus to support copying of analog signals from SCART 1 to SCART 2 and vice versa.

Unused internal registers may lose their information in standby mode. Therefore, the device needs to be initialized on returning to normal operation. This can be accomplished in the same way as after a power-on reset.

Digital TV Sound Processor (DTVSP)

TDA9875

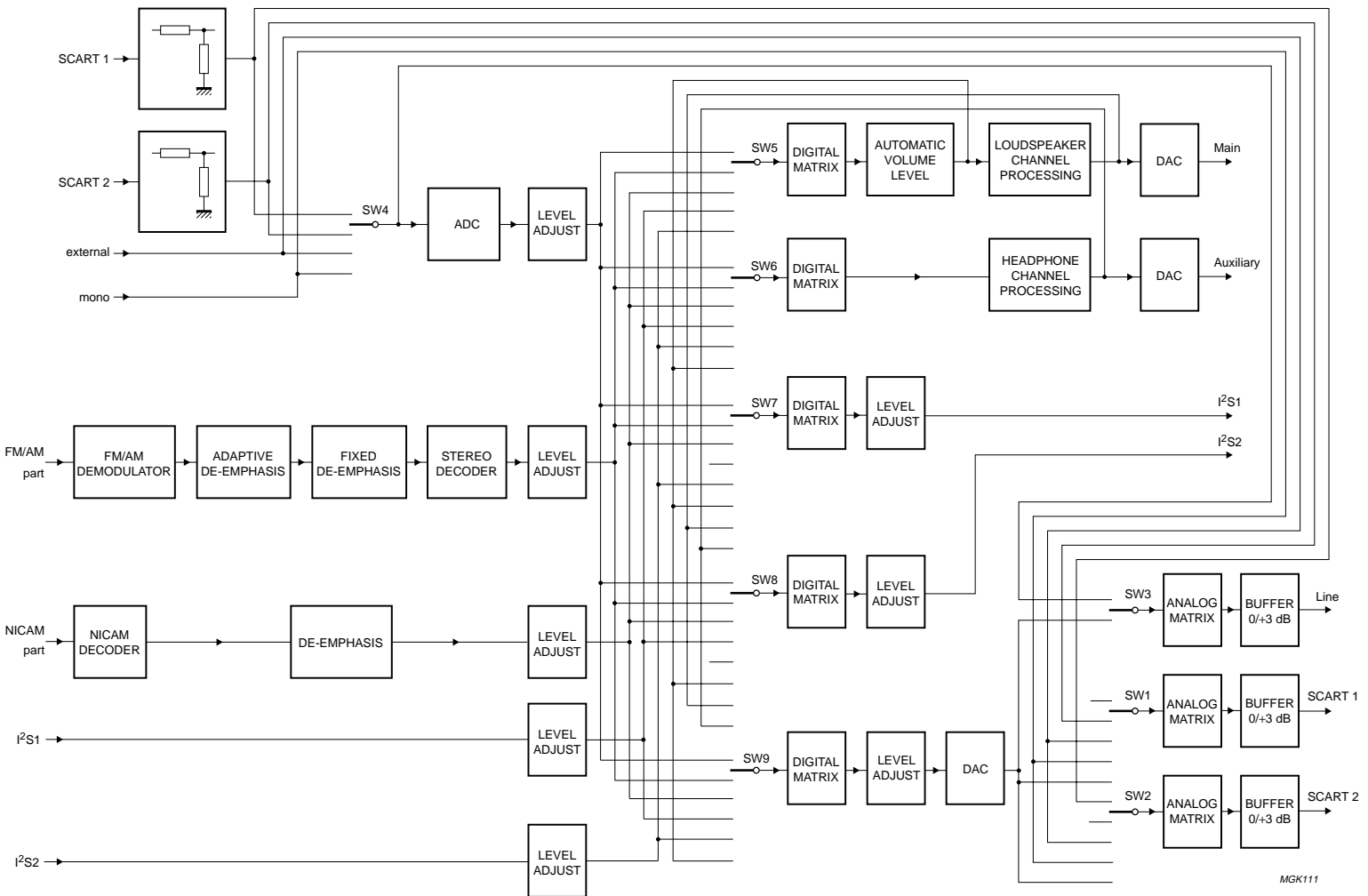

Fig.6 Audio signal flow diagram.

## Digital TV Sound Processor (DTVSP)

TDA9875

**7 LIMITING VALUES**

In accordance with the Absolute Maximum Rating System (IEC 134).

SYMBOL	PARAMETER	CONDITIONS	MIN.	MAX.	UNIT
$V_{DD}$	DC supply voltage		-0.5	+6.5	V
$\Delta V_{DD}$	voltage differences between two $V_{DD}$ pins		-	550	mV
$I_{IK}$	DC input clamping diode current	$V_I < -0.5$ V or $V_I > V_{DD} + 0.5$ V	-	$\pm 10$	mA
$I_{OK}$	DC output clamping diode current (output type 4 mA)	$V_O < -0.5$ V or $V_O > V_{DD} + 0.5$ V	-	$\pm 20$	mA
$I_O$	DC output source or sink current (output type 4 mA)	$-0.5$ V $< V_O < V_{DD} + 0.5$ V	-	$\pm 20$	mA
$I_{DD}, I_{SSD}$	DC $V_{DD}$ or $V_{SS}$ current per digital supply pin		-	$\pm 100$	mA
$I_{DDA}, I_{SSA}$	DC $V_{DD}$ or $V_{SS}$ current per analog supply pin		-	$\pm 50$	mA
$I_{lu(prot)}$	latch-up protection		100	-	mA
P/out	power dissipation per output		-	100	mW
$P_{tot}$	total power dissipation		-	1.3	W
$T_{stg}$	storage temperature		-55	+125	°C
$T_{amb}$	operating ambient temperature		-20	+70	°C
$V_{es}$	electrostatic handling	note 1	2000	-	V
		note 2	200	-	V

**Notes**

- Human body model: C = 100 pF; R = 1.5 k $\Omega$ .
- Machine model: C = 200 pF; L = 0.75  $\mu$ H; R = 0  $\Omega$ .

**8 THERMAL CHARACTERISTICS**

SYMBOL	PARAMETER	CONDITIONS	VALUE	UNIT
$R_{th\ j-a}$	thermal resistance from junction to ambient	in free air	31	K/W

## Digital TV Sound Processor (DTVSP)

TDA9875

**9 CHARACTERISTICS**

$V_{DD} = 5\text{ V}$ ;  $T_{amb} = 25\text{ °C}$ ; settings in accordance with B/G standard; FM deviation  $\pm 50\text{ kHz}$ ;  $f_{mod} = 1\text{ kHz}$ ; FM sound parameters in accordance with system A2; NICAM in accordance with "EBU specification"; 1 k $\Omega$  measurement source resistance for AF inputs; unless otherwise specified.

SYMBOL	PARAMETER	CONDITIONS	MIN.	TYP.	MAX.	UNIT
<b>Digital supplies</b>						
$V_{DDD1}$	digital supply voltage 1		4.75	5.0	5.5	V
$V_{SSD1}$	digital supply ground 1		–	0.0	–	V
$I_{DDD1}$	digital supply current 1	$V_{DDD1} = 5.5\text{ V}$	65	80	95	mA
		$V_{DDD1} = 5.0\text{ V}$	55	70	85	mA
$V_{DDD2}$	digital supply voltage 2		4.75	5.0	5.5	V
$V_{SSD2}$	digital supply ground 2		–	0.0	–	V
$I_{DDD2}$	digital supply current 2	$V_{DDD2} = 5.5\text{ V}$	50	65	80	mA
		$V_{DDD2} = 5.0\text{ V}$	45	55	65	mA
<b>Demodulator supplies and references</b>						
$V_{DDA1}$	analog supply voltage for demodulator part		4.75	5.0	5.5	V
$V_{SSA1}$	analog ground for demodulator part		–	0.0	–	V
$I_{DDA1}$	analog supply current for demodulator part	$V_{DDA} = 5.5\text{ V}$	20	26	31	mA
		$V_{DDA} = 5.0\text{ V}$	19	24	28	mA
$V_{ref1}$	analog reference voltage for demodulator part	referenced to $V_{DDA1}/V_{SSA1}$	35	50	65	%
$I_{ref1(sink)}$	$V_{ref1}$ sink current		170	220	260	$\mu\text{A}$
<b>Audio supplies and references</b>						
$V_{DDA2}$	analog supply voltage for audio ADC part		4.75	5.0	5.5	V
$V_{SSA2}$	analog ground for audio ADC part		–	0.0	–	V
$I_{DDA2}$	analog supply current for audio ADC part	$V_{DDA} = 5.5\text{ V}$	11	14	17	mA
		$V_{DDA} = 5.0\text{ V}$	10	13	16	mA
$V_{DDA3}$	analog supply voltage for audio DAC part		4.75	5.0	5.5	V
$V_{SSA3}$	analog ground for audio DAC part		–	0.0	–	V
$I_{DDA3}$	analog supply current for audio DAC part	$V_{DDA} = 5.5\text{ V}$ ; digital silence	9	12	14	mA
		$V_{DDA} = 5.0\text{ V}$ ; digital silence	8	11	13	mA
$V_{SSA4}$	analog ground for operational amplifier		–	0.0	–	V
$V_{SSG}$	ground, guard rings for analog-to-digital circuitry		–	0.0	–	V
$V_{ref2}$	reference voltage for audio ADCs	referenced to $V_{DDA2}/V_{SSA2}$	–	50	–	%

## Digital TV Sound Processor (DTVSP)

TDA9875

SYMBOL	PARAMETER	CONDITIONS	MIN.	TYP.	MAX.	UNIT
$Z_{V_{ref2}-V_{DDA2}}$	impedance $V_{ref2}$ to $V_{DDA2}$		–	20	–	$k\Omega$
$Z_{V_{ref2}-V_{SSA2}}$	impedance $V_{ref2}$ to $V_{SSA2}$		–	20	–	$k\Omega$
$V_{ref3}$	reference voltage for audio DAC and operational amplifier	referenced to $V_{DDA3}/V_{SSA3}$	–	50	–	%
$Z_{V_{ref3}-V_{DDA3}}$	impedance $V_{ref3}$ to $V_{DDA3}$		–	20	–	$k\Omega$
$Z_{V_{ref3}-V_{SSA3}}$	impedance $V_{ref3}$ to $V_{SSA3}$		–	20	–	$k\Omega$
<b>Digital inputs and outputs</b>						
INPUTS						
<i>CMOS level input, high drive, pull-down (pins TEST1 and TEST2)</i>						
$V_{IL}$	LOW level input voltage		–	–	1.6	V
$V_{IH}$	HIGH level input voltage		3.0	–	–	V
$C_i$	input capacitance		–	–	10	pF
$Z_i$	input impedance		–	50	–	$k\Omega$
<i>CMOS level input, hysteresis, high drive, pull-up (pin CRESET)</i>						
$V_{IL}$	LOW level input voltage		–	–	1.6	V
$V_{IH}$	HIGH level input voltage		3.0	–	–	V
$V_{hys}$	hysteresis voltage		–	$0.33V_{DDD}$	–	V
$C_i$	input capacitance		–	–	10	pF
$Z_i$	input impedance		–	50	–	$k\Omega$
INPUTS/OUTPUTS						
<i>I<sup>2</sup>C-bus level input with Schmitt trigger, open-drain output stage (pins SCL and SDA)</i>						
$V_{IL}$	LOW level input voltage		–	–	1.6	V
$V_{IH}$	HIGH level input voltage		3.0	–	–	V
$V_{HYS}$	hysteresis voltage		–	$0.33V_{DDD}$	–	V
$I_{LI}$	input leakage current		–	–	$\pm 10$	$\mu A$
$C_i$	input capacitance		–	–	10	pF
$V_{OL}$	LOW level output voltage		–	–	0.5	V
$C_L$	load capacitance	active pull-up	–	–	400	pF
		passive pull-up	–	–	200	pF
<i>TTL/CMOS level, high drive, 4 mA 3-state output stage, pull-up (pins PCLK, NICAM, ADDR1, ADDR2, P1, P2, SCK, WS, SDO1, SDO2, SDI1 and SDI2)</i>						
$V_{IL}$	LOW level input voltage		–	–	0.8	V
$V_{IH}$	HIGH level input voltage		2.0	–	–	V
$C_i$	input capacitance		–	–	10	pF
$V_{OL}$	LOW level output voltage	$I_{OL} = 3 \text{ mA}$	–	–	0.5	V
$V_{OH}$	HIGH level output voltage	$I_{OH} = -3 \text{ mA}$	2.9	–	–	V
$C_L$	load capacitance	active pull-up	–	–	50	pF
$Z_i$	input impedance		–	50	–	$k\Omega$

## Digital TV Sound Processor (DTVSP)

TDA9875

SYMBOL	PARAMETER	CONDITIONS	MIN.	TYP.	MAX.	UNIT
<b>OUTPUTS</b>						
<i>4 mA 3-state output stage (pin SYSCLK)</i>						
$V_{OL}$	LOW level output voltage	$I_{OL} = 2 \text{ mA}$	–	–	0.5	V
$V_{OH}$	HIGH level output voltage	$I_{OH} = -2 \text{ mA}$	2.9	–	–	V
$C_L$	load capacitance		–	–	50	pF
$I_{LIZ}$	3-state leakage current	$V_i = 0 \text{ to } V_{DDD}$	–	–	$\pm 10$	$\mu\text{A}$
<b>SIF1 and SIF2 analog inputs</b>						
$V_{SIFmax(rms)}$	maximum composite SIF input voltage (RMS value)		–	250	–	mV
$V_{SIFmin(rms)}$	minimum composite SIF input voltage (RMS value)		–	21	–	mV
AGC	AGC range		–	21	–	dB
$f_i$	input frequency		4	–	9.2	MHz
$R_i$	input resistance		10	13	16	$k\Omega$
$C_i$	input capacitance		–	7.5	11	pF
$\Delta f_{FM}$	FM deviation	B/G standard; THD < 1%	100	–	–	kHz
$\Delta f_{FM(FS)}$	FM deviation full-scale level	terrestrial FM; level adjust 0 dB	150	–	–	kHz
$C/N_{FM}$	FM carrier $C/N_c$ ratio	$N_{FM}$ bandwidth = 6 MHz; white noise for $S/N = 40 \text{ dB}$ ; "CCIR468"; quasi peak	–	77	–	$\frac{\text{dB}_{FM}}{\text{Hz}}$
$C/N_N$	NICAM carrier $C/N_c$ ratio	$N_c$ bandwidth = 6 MHz; bit error rate = $10^{-3}$ ; white noise	–	66	–	$\frac{\text{dB}_N}{\text{Hz}}$
$\alpha_{ct}$	crosstalk attenuation input channel	$f_i = 4 \text{ to } 9.2 \text{ MHz}$	50	–	–	dB
<b>Demodulator performance</b>						
THD + N	total harmonic distortion plus noise	from FM source to any output; $V_o = 1 \text{ V (RMS)}$	–	0.3	0.5	%
		from NICAM source to any output; $V_o = 1 \text{ V (RMS)}$	–	0.1	0.3	%
S/N	signal-to-noise ratio	SC1 from FM source to any output; $V_o = 1 \text{ V (RMS)}$ , TIMPOL bit HIGH	61	65	–	dB
		SC2 from FM source to any output; $V_o = 1 \text{ V (RMS)}$ , TIMPOL bit HIGH	57	60	–	dB
		NICAM source; $V_o = 1 \text{ V (RMS)}$	NICAM in accordance with "EBU specification"; note 2			

## Digital TV Sound Processor (DTVSP)

TDA9875

SYMBOL	PARAMETER	CONDITIONS	MIN.	TYP.	MAX.	UNIT
B <sub>-3</sub>	-3 dB bandwidth	from FM source to any output	14.5	15	–	kHz
		from NICAM source to any output	14.5	15	–	kHz
$\alpha_{ct}$	crosstalk attenuation	from SIF1 or SIF2 to any output	65	70	–	dB
$\alpha_{CS(stereo)}$	stereo channel separation		40	45	–	dB
$\alpha_{AM}$	AM suppression for FM	AM: 1 kHz, 30% modulation; reference: 1 kHz, 50 kHz deviation	50	–	–	dB
DEP <sub>D</sub>	de-emphasis		50 $\mu$ s, 60 $\mu$ s, 75 $\mu$ s, J17, adaptive de-emphasis			
S/N <sub>AM</sub>	AM demodulation	SIF level 100 mV (RMS); 54% AM; 1 kHz AF; "CCIR468", quasi peak	–	36	–	dB
IDENTIFICATION FOR FM SYSTEMS						
mod <sub>p</sub>	pilot modulation for identification		25	50	75	%
C/N <sub>p</sub>	pilot sideband C/N for identification start		–	32	–	$\frac{dB}{Hz}$
hys <sub>tun</sub>	hysteresis		–	–	2	dB
f <sub>ident</sub>	identification window	B/G stereo				
		slow mode	116.85	–	118.12	Hz
		medium mode	116.11	–	118.89	Hz
		fast mode	114.65	–	120.46	Hz
		B/G dual				
		slow mode	273.44	–	274.81	Hz
medium mode	272.07	–	276.20	Hz		
fast mode	270.73	–	277.60	Hz		
t <sub>ident(on)</sub>	total identification time ON	slow mode	–	–	2	s
		medium mode	–	–	1	s
		fast mode	–	–	0.5	s
t <sub>ident(off)</sub>	total identification time OFF	slow mode	–	–	2	s
		medium mode	–	–	1	s
		fast mode	–	–	0.5	s
<b>Analog audio inputs</b>						
MONO INPUT						
V <sub>i(nom)(rms)</sub>	nominal level input voltage (RMS value)	note 3	–	500	–	mV
V <sub>i(clip)(rms)</sub>	clipping level input voltage (RMS value)	THD < 3%; note 4	1250	1400	–	mV
R <sub>i</sub>	input resistance	note 4	28	35	42	k $\Omega$



## Digital TV Sound Processor (DTVSP)

TDA9875

SYMBOL	PARAMETER	CONDITIONS	MIN.	TYP.	MAX.	UNIT
<b>SCART AND EXTERNAL INPUTS</b>						
$V_{i(nom)(rms)}$	nominal level input voltage at input pin (RMS value)	-3 dB divider with external 15 k $\Omega$ resistor; notes 3 and 5	-	350	-	mV
$V_{i(clip)(rms)}$	clipping level input voltage at input pin (RMS value)	-3 dB divider with external 15 k $\Omega$ resistor; THD < 3%; notes 4 and 5	1250	1400	-	mV
$R_i$	input resistance	note 4	28	35	42	k $\Omega$
<b>Analog audio outputs</b>						
<b>LOUDSPEAKER (MAIN) AND HEADPHONE (AUXILIARY) OUTPUTS</b>						
$V_{o(clip)(rms)}$	clipping level output voltage (RMS value)	THD < 3%	1400	-	-	mV
$R_o$	output resistance		150	250	375	$\Omega$
$R_{L(AC)}$	AC load resistance		10	-	-	k $\Omega$
$R_{L(DC)}$	DC load resistance		10	-	-	k $\Omega$
$C_L$	output load capacitance		-	10	12	nF
$V_{offset(DC)}$	static DC offset voltage		-	30	70	mV
$\alpha_{mute}$	mute suppression	nominal input signal from any source; $f_i = 1$ kHz; note 3	80	-	-	dB
$G_{ro(main,aux)}$	roll-off gain at 14.5 kHz for Main and Auxiliary channels	from any source	-3	-2	-	dB
$PSRR_{main,aux}$	power supply ripple rejection for Main and Auxiliary channels	$f_{ripple} = 70$ Hz; $V_{ripple} = 100$ mV (peak); $C_{Vref} = 47$ $\mu$ F; signal from I <sup>2</sup> S-bus	40	45	-	dB
<b>SCART OUTPUTS AND LINE OUTPUT</b>						
$V_{o(nom)(rms)}$	nominal level output voltage (RMS value)	+3 dB amplification; note 3	-	500	-	mV
$V_{o(clip)(rms)}$	clipping level output voltage (RMS value)	THD < 3%	-	1400	-	mV
$R_o$	output resistance		150	250	375	$\Omega$
$R_{L(AC)}$	AC load resistance		10	-	-	k $\Omega$
$R_{L(DC)}$	DC load resistance		10	-	-	k $\Omega$
$C_L$	output load capacitance		-	-	2.5	nF
$V_{offset(DC)}$	static DC offset voltage	output amplifiers at +3 dB position	-	30	50	mV
$\alpha_{mute}$	mute suppression	nominal input signal from any source; $f_i = 1$ kHz; note 3	80	-	-	dB

## Digital TV Sound Processor (DTVSP)

TDA9875

SYMBOL	PARAMETER	CONDITIONS	MIN.	TYP.	MAX.	UNIT
B <sub>line</sub>	line bandwidth	from SCART, external, Auxiliary and mono sources; -3 dB bandwidth	20	-	-	kHz
		from DSP sources; -3 dB bandwidth	14.5	-	-	kHz
PSRR <sub>line</sub>	power supply ripple rejection	f <sub>ripple</sub> = 70 Hz; V <sub>ripple</sub> = 100 mV (peak); C <sub>Vref</sub> = 47 μF; signal from I <sup>2</sup> S-bus	40	45	-	dB
<b>Audio performance</b>						
THD + N	total harmonic distortion plus noise	V <sub>i</sub> = V <sub>o</sub> = 1 V (RMS); f <sub>i</sub> = 1 kHz; bandwidth 20 Hz to 15 kHz; note 1				
		from any analog audio input to I <sup>2</sup> S-bus	-	0.1	0.3	%
		from I <sup>2</sup> S-bus to any analog audio output	-	0.1	0.3	%
		SCART-to-SCART copy	-	0.1	0.3	%
		SCART-to-Main copy	-	0.2	0.5	%
S/N	signal-to-noise ratio	reference voltage V <sub>o</sub> = 1.4 V (RMS); f <sub>i</sub> = 1 kHz; "CCIR468"; quasi peak; note 1				
		from any analog audio input to I <sup>2</sup> S-bus	73	77	-	dB
		from I <sup>2</sup> S-bus to any analog audio output	78	90	-	dB
		SCART-to-SCART copy	78	90	-	dB
		SCART-to-Main copy	73	77	-	dB
α <sub>ct</sub>	crosstalk attenuation	between any analog input pairs; f <sub>i</sub> = 1 kHz	70	-	-	dB
		between any analog output pairs; f <sub>i</sub> = 10 kHz	65	-	-	dB
α <sub>CS</sub>	channel separation	between left and right of any input pair	65	-	-	dB
		between left and right of any output pair	60	-	-	dB
G <sub>A</sub>	from SCART-to-SCART with -3 dB input voltage divider	output amplifier in +3 dB position; R <sub>ext</sub> = 15 kΩ ±10%	-1.5	0	+1.1	dB
		output amplifier in 0 dB position; R <sub>ext</sub> = 15 kΩ ±10%	-4.5	-3.0	-1.9	dB
	from external input to loudspeaker	R <sub>ext</sub> = 15 kΩ ±10%; note 1	-1.5	0	+1.5	dB

## Digital TV Sound Processor (DTVSP)

TDA9875

SYMBOL	PARAMETER	CONDITIONS	MIN.	TYP.	MAX.	UNIT
<b>VCXO and clock generation</b>						
VCXO						
<i>Crystal input</i>						
$C_i$	input capacitance		–	–	10	pF
$V_{bias(DC)}$	DC bias voltage	$R_i = 100\text{ k}\Omega$	3.5	3.63	3.7	V
<i>Crystal output</i>						
$V_{osc(p-p)}$	oscillation amplitude (peak-to-peak value)		–	1.4	–	V
$V_{bias(DC)}$	DC bias voltage		2.0	2.4	2.8	V
$G_m$	mutual conductance at 24.576 MHz		16.6	17.6	18.8	$\frac{\text{mA}}{\text{V}}$
$C_o$	output capacitance		–	–	10	pF
CRYSTAL SPECIFICATION (FUNDAMENTAL MODE)						
$f_{xtal}$	crystal frequency		–	24.576	–	MHz
$C_L$	load capacitance		–	20	–	pF
$C_1$	series capacitance		–	20	–	fF
$C_0$	parallel capacitance		–	–	7	pF
$\Phi_{pull}$	pulling sensitivity	$C_L$ changed from 18 to 16 pF	–	25	–	$\frac{10^{-6}}{\text{pF}}$
$R_R$	equivalent series resistance	at nominal frequency	–	–	30	$\Omega$
$R_N$	equivalent series resistance of unwanted mode		$2R_R$	–	–	$\Omega$
$\Delta T$	temperature range		–20	+25	+70	$^{\circ}\text{C}$
$X_J$	adjustment tolerance		–	–	$\pm 30$	$10^{-6}$
$X_D$	drift	across temperature range	–	–	$\pm 30$	$10^{-6}$
$X_A$	ageing		–	–	$\pm 5$	$\frac{10^{-6}}{\text{year}}$

---

**Digital TV Sound Processor (DTVSP)****TDA9875**

---

**Notes to the characteristics**

1. ADC level adjust = +6 dB, all other level adjusts = 0 dB, if external -3 dB divider is used set output buffer gain to +3 dB, tone control to 0 dB, AVL off and volume control to 0 dB.
2. Due to companding, the quantization noise of the NICAM system limits signal-to-noise ratio to 62 dB (unweighted; RMS value).
3. Definition of nominal levels:  
The full-scale level for analog audio signals is  $V_{FS} = 1.4 \text{ V}$  (RMS). The nominal level at the digital crossbar switch is defined at -15 dB (full-scale).
  - a) Audio input nominal levels:  
SCART: 350 mV (at pin); -12 dB (full-scale)  
external, mono: 500 mV; -9 dB (full-scale)
  - b) FM/AM path nominal (maximum) levels:  
system M: 15 kHz deviation; -23.7 dB (full-scale)  
system B/G, D/K, I: 27 kHz deviation; -18.6 dB (full-scale)  
SAT stereo (maximum): 50 kHz deviation; -13.3 dB (full-scale)  
SAT mono (maximum): 85 kHz deviation; -8.7 dB (full-scale)  
AM: 54% modulation; full-scale SIF ADC; -20 dB (full-scale)
  - c) NICAM path nominal (maximum) levels:  
system B/G: -18.2 dB (full-scale)  
system I: -22.8 dB (full-scale)  
maximum level: 0.0 dB (full-scale).
4. If the supply voltage for the TDA9875 is switched off, because of the ESD protection circuitry, all audio input pins are short-circuited. To avoid a short-circuit at the SCART inputs a 15 k $\Omega$  resistor (-3 dB divider) has to be used.
5. The SCART specification allows a signal level of up to 2 V (RMS). Because of signal handling limitations due to the 5 V supply voltage for the TDA9875, there is a need for fixed 3 dB attenuators at the SCART inputs. To achieve SCART-to-SCART copies with 0 dB gain, there are +3 dB/0 dB amplifiers at the outputs of SCART 1 and SCART 2 and at the line output. The attenuator is realized by an internal resistor that works together with an external series resistor as a voltage divider. With this voltage divider the maximum SCART input signal level of 2 V (RMS) is scaled down to 1.4 V (RMS) at the input pin. To avoid clipping, the +3 dB gain must not be used if the SCART input signal is larger than 1.4 V (RMS).

## Digital TV Sound Processor (DTVSP)

## TDA9875

**10 I<sup>2</sup>C-BUS CONTROL****10.1 Introduction**

The TDA9875 is fully controlled via the I<sup>2</sup>C-bus. Control is exercised by writing data to one or more internal registers. Status information can be read from an array of registers to enable the controlling microcontroller determine whether any action is required.

The device has an I<sup>2</sup>C-bus slave transceiver, in accordance with the fast-mode specification, with a maximum speed of 400 kbits/s. Information concerning the I<sup>2</sup>C-bus can be found in brochure "*I<sup>2</sup>C-bus and how to use it*" (order number 9398 393 40011). To avoid conflicts in a real application with other ICs providing similar or complementary functions, there are four possible slave addresses available which can be selected by pins ADDR1 and ADDR2 (see Table 7).

**Table 7** Possible slave addresses

ADDR2	ADDR1	SLAVE ADDRESS A6 TO A0
0	0	1 0 1 1 0 0 0
0	1	1 0 1 1 0 0 1
1	0	1 0 1 1 0 1 0
1	1	1 0 1 1 0 1 1

The I<sup>2</sup>C-bus interface remains operational in the standby mode of the TDA9875 to allow control of the analog source selectors with regard to SCART-to-SCART copying.

The device will not respond to a 'general call' on the I<sup>2</sup>C-bus, i.e. when a slave address of 0000000 is sent by a master.

The data transmission between the microcontroller and the other I<sup>2</sup>C-bus controlled ICs is not disturbed when the supply voltage of the TDA9875 is not connected.

**10.2 Power-up state**

At power-up the device is in the following state:

- All outputs muted
- No sound carrier frequency loaded
- General-purpose I/O pins ready for input (HIGH)
- Input SIF1 selected with:
  - AGC on
  - Small hysteresis.
- Demodulators for both sound carriers set to FM with:
  - Identification for B/G, D/K, response time 1 s
  - Level adjust set to 0 dB
  - De-emphasis 50  $\mu$ s
  - Matrix set to mono.
- Main channel set to FM input with:
  - Spatial off
  - Pseudo off
  - AVL off
  - Volume mute
  - Bass flat
  - Treble flat
  - Contour off
  - Bass boost flat.
- Auxiliary channel set to FM input with:
  - Volume mute
  - Bass flat
  - Treble flat.
- Feature interface all outputs off
- Beeper off
- Monitoring of carrier 1 FM demodulator DC output.

After power-up a device initialization has to be performed via the I<sup>2</sup>C-bus to put the TDA9875 into the proper mode of operation, in accordance with the desired TV standard, audio control settings, etc.

# Digital TV Sound Processor (DTVSP)

# TDA9875

### 10.3 Slave receiver mode

As a slave receiver, the TDA9875 provides 46 registers for storing commands and data. These registers are accessed via so-called subaddresses. A subaddress can be thought of as a pointer to an internal memory location.

**Table 8** I<sup>2</sup>C-bus; slave address, subaddress and data format

S	SLAVE ADDRESS	0	ACK	SUBADDRESS	ACK	DATA	ACK	P
---	---------------	---	-----	------------	-----	------	-----	---

**Table 9** Explanation of Table 8

BIT	FUNCTION
S	START condition
SLAVE ADDRESS	7-bit device address
0	data direction bit (write to device)
ACK	acknowledge
SUBADDRESS	address of register to write to
DATA	data byte to be written into register
P	STOP condition

It is allowed to send more than one data byte per transmission to the TDA9875. In this event, the subaddress is automatically incremented after each data byte, resulting in storing the sequence of data bytes at successive register locations, starting at SUBADDRESS. A transmission can start at any valid subaddress. Each byte is acknowledged with ACK (acknowledge).

There is no 'wrap-around' of subaddresses.

Commands and data are processed as soon as they have been completely received. Functions requiring more than one byte will, thus, be executed only after all bytes for that function have been received. Should the transmission is terminated (STOP condition) before all bytes have been received, the incomplete data for that function are ignored.

**Table 10** Format for a transmission employing auto-increment of subaddresses

S	SLAVE ADDRESS	0	ACK	SUBADDRESS	ACK	DATA BYTE A <sup>(1)</sup>	DATA	ACK	P
---	---------------	---	-----	------------	-----	----------------------------	------	-----	---

**Note**

- 1. n data bytes with auto-increment of subaddresses.

Data patterns sent to the various subaddresses are not checked for being illegal or not at that address, except for the functions of volume, bass, treble control, bass boost and level adjust.

Detection of a STOP condition without a preceding acknowledge bit is regarded as a bus error. The last operation will not then be executed.

## Digital TV Sound Processor (DTVSP)

TDA9875

Table 11 Overview of the slave receiver registers (note 1)

SUBADDRESS (DECIMAL)	DATA								FUNCTION
	MSB				LSB				
0	X	X	X	g	g	g	g	g	AGC gain selection (ignored, if AGC off)
1	c	c	c	c	c	c	c	c	general configuration
2	p	X	X	m	m	s	s	s	monitor select, peak detector on/off
3	f	f	f	f	f	f	f	f	carrier 1 frequency; MS part
4	f	f	f	f	f	f	f	f	carrier 1 frequency
5	f	f	f	f	f	f	f	f	carrier 1 frequency; LS part
6	f	f	f	f	f	f	f	f	carrier 2 frequency; MS part
7	f	f	f	f	f	f	f	f	carrier 2 frequency
8	f	f	f	f	f	f	f	f	carrier 2 frequency; LS part
9	c	c	c	X	c	c	c	c	demodulator configuration
10	d	d	d	d	d	d	d	d	FM de-emphasis
11	X	X	X	X	X	m	m	m	FM matrix
12	X	X	X	l	l	l	l	l	channel 1 output level adjust
13	X	X	X	l	l	l	l	l	channel 2 output level adjust
14	X	X	c	c	X	X	c	c	NICAM configuration
15	X	X	X	l	l	l	l	l	NICAM output level adjust
16	l	l	l	l	l	l	l	l	NICAM lower error limit
17	u	u	u	u	u	u	u	u	NICAM upper error limit
18	m	m	m	m	m	m	m	m	audio mute control
19	g	m	m	m	g	s	s	s	DAC output select
20	X	g	m	m	X	s	s	s	SCART 1 output select
21	X	g	m	m	X	s	s	s	SCART 2 output select
22	X	g	m	m	X	X	X	s	line output select
23	s	s	s	l	l	l	l	l	ADC output select
24	X	m	m	m	X	s	s	s	Main channel select
25	X	X	s	s	p	p	a	a	audio effects (AVL, pseudo, spatial)
26	v	v	v	v	v	v	v	v	volume control, Main left
27	v	v	v	v	v	v	v	v	volume control, Main right
28	X	X	X	c	c	c	c	c	contour control, Main
29	X	X	X	b	b	b	b	b	bass control, Main
30	X	X	X	t	t	t	t	t	treble control, Main
31	X	m	m	m	X	s	s	s	Auxiliary channel select
32	v	v	v	v	v	v	v	v	volume control, Auxiliary left
33	v	v	v	v	v	v	v	v	volume control, Auxiliary right
34	X	X	X	b	b	b	b	b	bass control, Auxiliary
35	X	X	X	t	t	t	t	t	treble control, Auxiliary
36	X	X	X	c	c	c	c	c	feature interface configuration
37	X	m	m	m	X	s	s	s	I <sup>2</sup> S1 output select

## Digital TV Sound Processor (DTVSP)

TDA9875

SUBADDRESS (DECIMAL)	DATA								FUNCTION
	MSB				LSB				
38	X	X	X	i	i	i	i	i	I <sup>2</sup> S1 input level adjust
39	X	X	X	o	o	o	o	o	I <sup>2</sup> S1 output level adjust
40	X	m	m	m	X	s	s	s	I <sup>2</sup> S2 output select
41	X	X	X	i	i	i	i	i	I <sup>2</sup> S2 input level adjust
42	X	X	X	o	o	o	o	o	I <sup>2</sup> S2 output level adjust
43	X	X	X	X	X	f	f	f	beeper frequency
44	X	X	v	v	v	v	v	v	beeper volume, Main and Auxiliary
45	b	b	b	b	b	b	b	b	bass boost, Main left and right

**Note**

1. X indicates bits that have not yet been assigned to a function. Their meaning is 'don't care'. They should be written as a zero.

The following sub-sections provide a detailed description of the slave receiver registers:

### 10.3.1 AGC GAIN REGISTER

#### 10.3.1.1 Description

If the automatic gain control function is switched off in the General Configuration Register, the contents of this register will define a fixed gain of the AGC stage. The input voltages given are meant to generate a full-scale output from the SIF ADC. If automatic gain control is on, the contents of this register is ignored.

It should be noted that the input voltages should be considered as approximate target values.



## Digital TV Sound Processor (DTVSP)

TDA9875

## 10.3.1.2 Definition

Table 12 Subaddress 0 (notes 1 and 2)

MSB							LSB		SIF INPUT VOLTAGE [mV (RMS)]
B7	B6	B5	B4	B3	B2	B1	B0		
X	X	X	1	1	1	1	1	240	
X	X	X	1	1	1	1	0	214	
X	X	X	1	1	1	0	1	195	
X	X	X	1	1	1	0	0	176	
X	X	X	1	1	0	1	1	159	
X	X	X	1	1	0	1	0	145	
X	X	X	1	1	0	0	1	131	
X	X	X	1	1	0	0	0	119	
X	X	X	1	0	1	1	1	107	
X	X	X	1	0	1	1	0	99	
X	X	X	1	0	1	0	1	90	
X	X	X	1	0	1	0	0	82	
X	X	X	1	0	0	1	1	76	
X	X	X	1	0	0	1	0	70	
X	X	X	1	0	0	0	1	65	
X	X	X	1	0	0	0	0	60	
X	X	X	0	1	1	1	1	55	
X	X	X	0	1	1	1	0	51	
X	X	X	0	1	1	0	1	48	
X	X	X	0	1	1	0	0	45	
X	X	X	0	1	0	1	1	42	
X	X	X	0	1	0	1	0	39	
X	X	X	0	1	0	0	1	36	
X	X	X	0	1	0	0	0	34	
X	X	X	0	0	1	1	1	32	
X	X	X	0	0	1	1	0	30	
X	X	X	0	0	1	0	1	29	
X	X	X	0	0	1	0	0	27	
X	X	X	0	0	0	1	1	25	
X	X	X	0	0	0	1	0	24	
X	X	X	0	0	0	0	1	23	
X	X	X	0	0	0	0	0	22	

## Notes

1. X = don't care.
2. The default setting at power-up is 00000000.

## Digital TV Sound Processor (DTVSP)

TDA9875

## 10.3.2 GENERAL CONFIGURATION REGISTER

## 10.3.2.1 Description

**Table 13** Description of Table 14

NAME	HIGH/LOW	FUNCTION
SIFSEL	HIGH	Selects pin SIF2 for input (recommended for satellite tuner).
	LOW	Pin SIF1 (terrestrial TV) is selected.
AGCOFF	HIGH	Forces the AGC block to a fixed gain as defined in the AGC gain register.
	LOW	The automatic gain control function is enabled and the contents of the AGC gain register is ignored.
AGCSLOW	HIGH	A longer decay time and larger hysteresis are selected for input signals with strong video modulation (intercarrier). This bit only has an effect when bit AGCOFF = 0.
	LOW	Selects normal attack and decay times for the AGC and a small hysteresis.
INIT	HIGH	Causes initialization of TDA9875 to its default settings. This has the same effect as a power-on reset. If there is a conflict between the default settings and any bit set HIGH in this register, the bits of this register have priority over the corresponding default setting.
	LOW	This bit is automatically reset to LOW after initialization. When set LOW, the TDA9875 is in its normal mode of operation.
STDBY	HIGH	Puts the TDA9875 into the standby mode. Most functions are disabled and power dissipation is somewhat reduced, but the analog selectors/matrices remain operational to support analog copying from SCART 1 to SCART 2 and vice versa.
	LOW	The TDA9875 is in its normal mode of operation. On return from standby mode, the device is in its power-on reset mode and needs to be re-initialized.
P1OUT, P2OUT	–	These bits control the general purpose input/output pins. The contents of these bits is written directly to the corresponding pins. If input is desired, the bits must be set HIGH to allow the pins to be pulled LOW externally. Input from the pins is reflected in the device status register (see Section 10.4, subaddress 0). P1OUT is recommended to be used for switching an SIF trap for the adjacent picture carrier in designs that employ such a trap.

## 10.3.2.2 Definition

**Table 14** Subaddress 1 (note 1)

BIT	NAME	DESCRIPTION
7 (MSB)	P2OUT	general purpose I/O pin 2
6	P1OUT	general purpose I/O pin 1
5	STDBY	stand-by mode on/off
4	INIT	initialize to defaults (as reset)
3	X	don't care
2	AGCSLOW	AGC decay time
1	AGCOFF	AGC on/off
0 (LSB)	SIFSEL	SIF input select

**Note**

1. The default setting at power-up is 11000000.

# Digital TV Sound Processor (DTVSP)

# TDA9875

## 10.3.3 MONITOR SELECT REGISTER

### 10.3.3.1 Description

This register is used to define the signal source, the level of which is to be monitored, and if the peak level is to be monitored. Peak level refers to the magnitude of the maximum excursion of a signal. Data can be read-out in the I<sup>2</sup>C-bus slave transmitter mode (see Section 10.4, subaddresses 5 and 6).

Audio magnitude/phase is related to the FM demodulator output. Phase information is provided, when it operates in FM mode, while magnitude is supplied in AM mode.

**Table 15** Description of bit PEAKMON

NAME	HIGH/LOW	FUNCTION
PEAKMON	HIGH	selects the peak level of a source to be monitored
	LOW	the last sample will be supplied

### 10.3.3.2 Definition

**Table 16** Subaddress 2 (notes 1, 2 and 3)

MSB						LSB	
B7	B6	B5	B4	B3	B2	B1	B0
PEAKMON	X	X	see Table 18		see Table 17		

#### Notes

1. X = don't care.
2. PEAKMON is described in Section 10.3.3.1.
3. The default setting at power-up is 00000000.

**Table 17** Signal source (note 1)

B2	B1	B0	SIGNAL SOURCE
0	0	0	DC output of FM demodulator
0	0	1	audio magnitude/phase, FM demodulator output
0	1	0	crossbar input from FM/AM channel
0	1	1	crossbar input from NICAM channel
1	0	0	crossbar input from I <sup>2</sup> S1 channel
1	0	1	crossbar input from I <sup>2</sup> S2 channel
1	1	0	crossbar input from audio ADC channel
1	1	1	input to Main channel DAC (without beeper)

#### Note

1. The term 'crossbar' refers to the digital selector, where level-adjusted signals from various sources are available.

## Digital TV Sound Processor (DTVSP)

## TDA9875

**Table 18** Monitor output

B4	B3	MONITOR OUTPUT
0	0	$\frac{\text{L input} + \text{R input}}{2}$
0	1	L input (channel 1, respectively)
1	0	R input (channel 2, respectively)

**10.3.3.3 Note**

By reading out Level Read-out Registers (subaddresses 5 and 6, see Section 10.4), the current peak level will be reset.

**10.3.4 CARRIER 1 FREQUENCY REGISTER****10.3.4.1 Description**

The three bytes together constitute a 24-bit frequency control word to represent the sound carrier (i.e. mixer) frequency in accordance with the following formula:

$$\text{data} = \frac{f_{\text{mix}}}{f_{\text{clk}}} \times 2^{24}$$

Where:

Data = 24-bit frequency control word

$f_{\text{mix}}$  = desired sound carrier frequency

$f_{\text{clk}}$  = 12.288 MHz (clock frequency of mixer)

$2^{24}$  = 16777216 (number of steps in a 24-bit word size).

Example: A 5.5 MHz sound carrier frequency will be generated by sending the following sequence of data bytes to the TDA9875 (data = 7509333 in decimal notation or 729555 in hex): 01110010 10010101 01010101.

As three bytes are required to define a carrier frequency, execution of this command starts only after all bytes have been received. If an error occurs, e.g. a premature STOP condition, partial data for this function is ignored.

The default setting at power-up is 00000000 for all three bytes.

**10.3.4.2 Definition**

Most significant part at subaddress 3.

**Table 19** Subaddresses 3 to 5

BIT	SUBADDRESSES
7 (MSB)	3
6	
5	
4	
3	
2	
1	
0	
7	4
6	
5	
4	
3	
2	
1	
0	
7	5
6	
5	
4	
3	
2	
1	
0 (LSB)	

**10.3.5 CARRIER 2 FREQUENCY REGISTER****10.3.5.1 Description**

Same as for sound carrier 1.

If the carrier 2 frequency register is used, it will be for either the second FM sound carrier of a terrestrial or satellite FM program or the NICAM sound carrier.

**10.3.5.2 Definition**

Subaddresses 6 to 8.

Same as for sound carrier 1, except for subaddresses used.

## Digital TV Sound Processor (DTVSP)

TDA9875

## 10.3.6 DEMODULATOR CONFIGURATION REGISTER

## 10.3.6.1 Definition

**Table 20** Subaddress 9 (note 1; see Table 23)

BIT	NAME	DESCRIPTION
7 (MSB)	IDMOD1	response time for FM sound mode identification
6	IDMOD0	
5	IDAREA	application area for FM identification
4	X	don't care
3	CH2MOD1	channel 2 receive mode
2	CH2MOD0	
1	CH1WIDE	channel 1 bandwidth
0 (LSB)	CH1MODE	channel 1 receive mode

**Note**

1. The default setting at power-up is 00000000.

**Table 21** Channel 2 receive mode (see Table 20)

B3	B2	CHANNEL 2
0	0	FM
0	1	AM
1	0	NICAM

**Table 22** Identification mode (see Table 20)

B7	B6	IDENT MODE
0	0	slow
0	1	medium
1	0	fast
1	1	off/reset

## Digital TV Sound Processor (DTVSP)

TDA9875

## 10.3.6.2 Description

**Table 23** Description of subaddress 9 (notes 1 and 2)

NAME	HIGH/LOW	FUNCTION
CH1MODE	HIGH	Selects the hardware for the first sound carrier to operate in AM mode.
	LOW	FM mode is assumed. This applies to both terrestrial and satellite FM reception.
CH1WIDE	HIGH	Switches the decimation filters for the first sound carrier to a wide bandwidth, so that the main sound carrier of a satellite channel with its larger deviation can be handled without additional distortion.
	LOW	The bandwidth is narrow to cope with the intermodulation requirements of FM stereo.
CH2MOD0, CH2MOD1	–	These bits control the hardware for the second sound carrier in accordance with the truth Table 21. The NICAM mode employs a wider bandwidth of the decimation filters than the FM mode.
IDAREA	HIGH	Selects FM identification frequencies in accordance with the specification for Korea.
	LOW	Frequencies for Europe are selected (B/G and D/K standard).
IDMOD0, IDMOD1	–	These bits define the response time after which a sound mode identification result may be expected. The longer the time, the more reliable the identification.

**Notes**

1. It is recommended to switch the FM sound mode identification off whenever the received program is not a terrestrial 2-carrier sound.
2. Switching the identification off will reset the associated hardware to a defined state.

## 10.3.7 FM DE-EMPHASIS REGISTER

## 10.3.7.1 Description

This register is used to select the proper de-emphasis characteristics as appropriate for the standard of the received carrier. Bits B3 to B0 apply to sound carrier 1, bits B7 to B4 apply to sound carrier 2. In the event of FM stereo reception, both groups must be set to the same characteristics.

## 10.3.7.2 Definition

**Table 24** Subaddress 10 (note 1)

BIT	NAME	DESCRIPTION
7 (MSB)	ADEEM2	adaptive de-emphasis on/off
6		time constant selection for FM de-emphasis
5		
4		
3	ADEEM1	adaptive de-emphasis on/off
2		time constant selection for FM de-emphasis
1		
0 (LSB)		

**Note**

1. The default setting at power-up is 00000000.

Digital TV Sound Processor (DTVSP)

TDA9875

**Table 25** De-emphasis

B6 and B2	B5 and B1	B4 and B0	DE-EMPHASIS
0	0	0	50 μs (Europe)
0	0	1	60 μs
0	1	0	75 μs (M standard)
0	1	1	J17
1	0	0	off

**Table 26** Description of bits ADEEM1 and ADEEM2 (note 1)

NAME	HIGH/LOW	FUNCTION
ADEEM1, ADEEM2	HIGH	Activates the adaptive de-emphasis function, which is required for certain satellite FM channels. The standard FM de-emphasis must then be set to 75 μs.
	LOW	The adaptive de-emphasis is off.

**Note**

1. The FM de-emphasis gain is 0 dB at 40 Hz.

10.3.8 FM MATRIX REGISTER

10.3.8.1 Description

This register is used to select the proper dematrixing characteristics as appropriate for the standard of the received carrier and the related sound mode identification. For the dematrixing, it is assumed that the output from sound carrier 1 is on channel L input.

10.3.8.2 Definition

**Table 27** Subaddress 11 (notes 1 and 2)

MSB							LSB
B7	B6	B5	B4	B3	B2	B1	B0
X	X	X	X	X	see Table 28		

**Notes**

1. X = don't care.
2. The default setting at power-up is 00000000.

**Table 28** Description of Subaddress 11 (bits B2 to B0)

B2	B1	B0	L OUTPUT	R OUTPUT	MODE
0	0	0	L input	L input	mono 1
0	0	1	R input	R input	mono 2
0	1	0	L input	R input	dual
0	1	1	R input	L input	dual swapped
1	0	0	2L input – R input	R input	stereo Europe
1	0	1	$\frac{L \text{ input} + R \text{ input}}{2}$	$\frac{L \text{ input} - R \text{ input}}{2}$	stereo Korea

# Digital TV Sound Processor (DTVSP)

# TDA9875

## 10.3.9 CHANNEL 1 OUTPUT LEVEL ADJUST REGISTER

### 10.3.9.1 Description

This register is used to correct for standard and station-dependent differences of signal levels. Table 29 applies to sound carrier 1.

### 10.3.9.2 Definition

**Table 29** Subaddress 12 (notes 1 and 2)

MSB							LSB		GAIN SETTING (dB)
B7	B6	B5	B4	B3	B2	B1	B0		
X	X	X	0	1	1	1	1	+15	
X	X	X	0	1	1	1	0	+14	
X	X	X	0	1	1	0	1	+13	
X	X	X	0	1	1	0	0	+12	
X	X	X	0	1	0	1	1	+11	
X	X	X	0	1	0	1	0	+10	
X	X	X	0	1	0	0	1	+9	
X	X	X	0	1	0	0	0	+8	
X	X	X	0	0	1	1	1	+7	
X	X	X	0	0	1	1	0	+6	
X	X	X	0	0	1	0	1	+5	
X	X	X	0	0	1	0	0	+4	
X	X	X	0	0	0	1	1	+3	
X	X	X	0	0	0	1	0	+2	
X	X	X	0	0	0	0	1	+1	
X	X	X	0	0	0	0	0	0	
X	X	X	1	1	1	1	1	-1	
X	X	X	1	1	1	1	0	-2	
X	X	X	1	1	1	0	1	-3	
X	X	X	1	1	1	0	0	-4	
X	X	X	1	1	0	1	1	-5	
X	X	X	1	1	0	1	0	-6	
X	X	X	1	1	0	0	1	-7	
X	X	X	1	1	0	0	0	-8	
X	X	X	1	0	1	1	1	-9	
X	X	X	1	0	1	1	0	-10	
X	X	X	1	0	1	0	1	-11	
X	X	X	1	0	1	0	0	-12	
X	X	X	1	0	0	1	1	-13	
X	X	X	1	0	0	1	0	-14	
X	X	X	1	0	0	0	1	-15	
X	X	X	1	0	0	0	0	mute	

**Notes**

1. X = don't care.
2. The default setting at power-up is 00000000.



## Digital TV Sound Processor (DTVSP)

TDA9875

## 10.3.10 CHANNEL 2 OUTPUT LEVEL ADJUST REGISTER

## 10.3.10.1 Description

This register is used to correct for standard and station-dependent differences of signal levels. Table 30 applies to sound carrier 2 in its FM and AM modes. In the event of FM stereo or FM dual language reception, channels 1 and 2 should be adjusted to the same level.

## 10.3.10.2 Definition

**Table 30** Subaddress 13 (notes 1 and 2)

MSB							LSB	GAIN SETTING (dB)
B7	B6	B5	B4	B3	B2	B1	B0	
X	X	X	0	1	1	1	1	+15
X	X	X	0	1	1	1	0	+14
X	X	X	0	1	1	0	1	+13
X	X	X	0	1	1	0	0	+12
X	X	X	0	1	0	1	1	+11
X	X	X	0	1	0	1	0	+10
X	X	X	0	1	0	0	1	+9
X	X	X	0	1	0	0	0	+8
X	X	X	0	0	1	1	1	+7
X	X	X	0	0	1	1	0	+6
X	X	X	0	0	1	0	1	+5
X	X	X	0	0	1	0	0	+4
X	X	X	0	0	0	1	1	+3
X	X	X	0	0	0	1	0	+2
X	X	X	0	0	0	0	1	+1
X	X	X	0	0	0	0	0	0
X	X	X	1	1	1	1	1	-1
X	X	X	1	1	1	1	0	-2
X	X	X	1	1	1	0	1	-3
X	X	X	1	1	1	0	0	-4
X	X	X	1	1	0	1	1	-5
X	X	X	1	1	0	1	0	-6
X	X	X	1	1	0	0	1	-7
X	X	X	1	1	0	0	0	-8
X	X	X	1	0	1	1	1	-9
X	X	X	1	0	1	1	0	-10
X	X	X	1	0	1	0	1	-11
X	X	X	1	0	1	0	0	-12
X	X	X	1	0	0	1	1	-13

## Digital TV Sound Processor (DTVSP)

TDA9875

MSB							LSB	GAIN SETTING (dB)
B7	B6	B5	B4	B3	B2	B1	B0	
X	X	X	1	0	0	1	0	-14
X	X	X	1	0	0	0	1	-15
X	X	X	1	0	0	0	0	mute

**Notes**

1. X = don't care.
2. The default setting at power-up is 00000000.

## 10.3.11 NICAM CONFIGURATION REGISTER

## 10.3.11.1 Definition

**Table 31** Subaddress 14 (note 1)

BIT	NAME	DESCRIPTION
7 (MSB)	X	don't care
6	X	don't care
5	TIMPOL	timing loop polarity
4	DOUTEN	data output enable
3	X	don't care
2	X	don't care
1	NDEEM	de-emphasis on/off
0 (LSB)	AMUTE	auto-muting on/off

**Note**

1. The default setting at power-up is 00000000.

## Digital TV Sound Processor (DTVSP)

TDA9875

## 10.3.11.2 Description

**Table 32** Description of Table 31 (notes 1, 2 and 3)

NAME	HIGH/LOW	FUNCTION
AMUTE	HIGH	Automatic muting is disabled. This bit has only an effect when the second sound carrier is set to NICAM.
	LOW	enables the automatic switching between NICAM and the program on the first sound carrier (i.e. FM mono or AM), dependent on the NICAM bit error rate
NDEEM	HIGH	switches the NICAM J17 de-emphasis off
	LOW	switches the NICAM J17 de-emphasis on
DOUTEN	HIGH	enables the output of the NICAM serial data stream from the DQPSK demodulator and of the associated clock, PCLK
	LOW	both outputs will be 3-stated
TIMPOL	HIGH	Inverts the polarity. This feature can be used to compensate for the phase shift that is introduced by an external inverting amplifier at the pin $V_{\text{tune}}$ . Such an amplifier could be used to provide a larger tuning voltage swing for the VCXO.
	LOW	sets the NICAM timing loop to normal polarity

**Notes**

1. The decision of whether auto-muting is permitted shall be taken by the controlling microcontroller based on information contained in the TDA9875's status registers. Thus, it depends on the strategy implemented in the software whether the auto-mute function is in accordance with "NICAM 728 ETS Revised for Data Applications" or any other preference.
2. The NICAM de-emphasis gain is 0 dB at 40 Hz.
3. In FM mode of sound carrier 2, the TIMPOL bit can be used to switch pin  $V_{\text{tune}}$  HIGH or LOW.

## 10.3.12 NICAM OUTPUT LEVEL ADJUST REGISTER

## 10.3.12.1 Description

This register is used to correct for standard and station-dependent differences of signal levels. Table 33 applies to both NICAM sound outputs.

## 10.3.12.2 Definition

**Table 33** Subaddress 15 (notes 1 and 2)

MSB							LSB		GAIN SETTING (dB)
B7	B6	B5	B4	B3	B2	B1	B0		
X	X	X	0	1	1	1	1	+15	
X	X	X	0	1	1	1	0	+14	
X	X	X	0	1	1	0	1	+13	
X	X	X	0	1	1	0	0	+12	
X	X	X	0	1	0	1	1	+11	
X	X	X	0	1	0	1	0	+10	
X	X	X	0	1	0	0	1	+9	
X	X	X	0	1	0	0	0	+8	
X	X	X	0	0	1	1	1	+7	

## Digital TV Sound Processor (DTVSP)

TDA9875

MSB							LSB		GAIN SETTING (dB)
B7	B6	B5	B4	B3	B2	B1	B0		
X	X	X	0	0	1	1	0	+6	
X	X	X	0	0	1	0	1	+5	
X	X	X	0	0	1	0	0	+4	
X	X	X	0	0	0	1	1	+3	
X	X	X	0	0	0	1	0	+2	
X	X	X	0	0	0	0	1	+1	
X	X	X	0	0	0	0	0	0	
X	X	X	1	1	1	1	1	-1	
X	X	X	1	1	1	1	0	-2	
X	X	X	1	1	1	0	1	-3	
X	X	X	1	1	1	0	0	-4	
X	X	X	1	1	0	1	1	-5	
X	X	X	1	1	0	1	0	-6	
X	X	X	1	1	0	0	1	-7	
X	X	X	1	1	0	0	0	-8	
X	X	X	1	0	1	1	1	-9	
X	X	X	1	0	1	1	0	-10	
X	X	X	1	0	1	0	1	-11	
X	X	X	1	0	1	0	0	-12	
X	X	X	1	0	0	1	1	-13	
X	X	X	1	0	0	1	0	-14	
X	X	X	1	0	0	0	1	-15	
X	X	X	1	0	0	0	0	mute	

**Notes**

1. X = don't care.
2. The default setting at power-up is 00000000.

## 10.3.13 NICAM LOWER ERROR LIMIT REGISTER

## 10.3.13.1 Description

When the auto-mute function is enabled (bit AMUTE in the NICAM configuration register) and the NICAM bit error count is lower than the value contained in this register, the NICAM signal is reselected for reproduction, see Section 10.3.14.

## 10.3.13.2 Definition

**Table 34** Subaddress 16 (notes 1 and 2)

MSB							LSB	
B7	B6	B5	B4	B3	B2	B1	B0	

**Notes**

1. The default setting at power-up is 00010100.
2. The lower bit error rate limit  $\cong$  subaddress 16  $\times$   $1.74 \times 10^{-5}$ .

## Digital TV Sound Processor (DTVSP)

TDA9875

## 10.3.14 NICAM UPPER ERROR LIMIT REGISTER

## 10.3.14.1 Description

When the auto-mute function is enabled (bit AMUTE in the NICAM configuration register) and the NICAM bit error count is higher than the value contained in this register, the signal of the first sound carrier (i.e. FM mono or AM sound) is selected for reproduction.

The difference between upper and lower error limit constitutes a hysteresis to avoid frequent switching between NICAM and the program on the first sound carrier.

## 10.3.14.2 Definition

**Table 35** Subaddress 17 (notes 1 and 2)

MSB							LSB
B7	B6	B5	B4	B3	B2	B1	B0

**Notes**

1. The default setting at power-up is 01010000.
2. The lower bit error rate limit  $\cong$  subaddress 16  $\times$  1.74  $\times$  10<sup>-5</sup>.

## 10.3.15 AUDIO MUTE CONTROL REGISTER

## 10.3.15.1 Description

When any of these bits are set HIGH, the corresponding pair of output channels will be muted. A LOW bit allows normal signal output.

There is a soft-mute facility for the Main and Auxiliary output channels to provide click-free muting independent of the volume control. This is switched on/off by bits MUTMAIN and MUTAUX.

## 10.3.15.2 Definition

**Table 36** Subaddress 18 (note 1)

BIT	NAME	DESCRIPTION
7 (MSB)	MUTI <sup>2</sup> S2	mute I <sup>2</sup> S2 outputs
6	MUTI <sup>2</sup> S1	mute I <sup>2</sup> S1 outputs
5	MUTDAC	mute internal DAC
4	MUTLINE	mute line outputs
3	MUTSC2	mute SCART 2 outputs
2	MUTSC1	mute SCART 1 outputs
1	MUTAUX	mute Auxiliary outputs
0 (LSB)	MUTMAIN	mute Main channels

**Note**

1. The default setting at power-up is 11111111.

## Digital TV Sound Processor (DTVSP)

TDA9875

## 10.3.16 DAC OUTPUT SELECT REGISTER

## 10.3.16.1 Description

This register is used to define both the signal source to be entered into the DAC and the mode of the digital matrix for signal selection. The DAC is used for signal output from digital sources at analog outputs.

The two combinations of FM and NICAM apply to the (rare) condition that three different languages are being broadcast in an FM + NICAM system. They allow for a two-out-of-three selection for external use, such as recording.

## 10.3.16.2 Definition

**Table 37** Subaddress 19 (note 1)

MSB				LSB			
B7	B6	B5	B4	B3	B2	B1	B0
DACGAIN2 <sup>(2)</sup>	see Table 39			DACGAIN1 <sup>(2)</sup>	see Table 38		

**Notes**

1. The default setting at power-up is 00000000.
2. See Table 40.

**Table 38** Signal source left and right

B2	B1	B0	SIGNAL SOURCE	
			LEFT	RIGHT
0	0	0	FM left	FM right
0	0	1	NICAM left	NICAM right
0	1	0	I <sup>2</sup> S1 left	I <sup>2</sup> S1 right
0	1	1	I <sup>2</sup> S2 left	I <sup>2</sup> S2 right
1	0	0	ADC left	ADC right
1	0	1	AVL left	AVL right
1	1	0	FM mono	NICAM M1
1	1	1	FM mono	NICAM M2

**Table 39** Bits B6 to B4 (note 1)

B6	B5	B4	L OUTPUT	R OUTPUT
0	0	0	L input	R input
0	0	1	L input	L input
0	1	0	R input	R input
0	1	1	R input	L input
1	X	X	$\frac{L+R}{2}$	$\frac{L+R}{2}$

**Note**

1. X = don't care.

Digital TV Sound Processor (DTVSP)

TDA9875

**Table 40** Description of bits DACGAIN1 and DACGAIN2

NAME	HIGH/LOW	FUNCTION
DACGAIN1, DACGAIN2	HIGH	These bits can introduce some extra gain at the input to the DAC. DACGAIN1 adds 3 dB and DACGAIN2 adds 6 dB of gain, respectively.
	LOW	Sets a gain of 0 dB.

10.3.17 SCART 1 OUTPUT SELECT REGISTER

10.3.17.1 Description

This register is used to define both the signal source to be output at SCART 1 and the output channel selector mode.

10.3.17.2 Definition

**Table 41** Subaddress 20 (notes 1 and 2)

MSB							LSB
B7	B6	B5	B4	B3	B2	B1	B0
X	SC1GAIN <sup>(3)</sup>	see Table 43		X	see Table 42		

**Notes**

1. X = don't care.
2. The default setting at power-up is 00000001.
3. See Table 44.

**Table 42** Signal source

B2	B1	B0	SIGNAL SOURCE
0	0	1	SCART 2 input
0	1	0	external input
0	1	1	mono input
1	0	0	DAC input

**Table 43** Bits B5 and B4

B5	B4	L OUTPUT	R OUTPUT
0	0	L input	R input
0	1	L input	L input
1	0	R input	R input
1	1	R input	L input

# Digital TV Sound Processor (DTVSP)

# TDA9875

**Table 44** Description of bit SC1GAIN (note 1)

NAME	HIGH/LOW	FUNCTION
SC1GAIN	HIGH	Activates the 3 dB gain stage at the SCART 1 output port. As any SCART input passes a 3 dB attenuator, this gain stage can be used to compensate that attenuation, resulting in a 0 dB insertion loss when copying from SCART 2 input to SCART 1 output. However, that gain must be used with great care, as it will cause signal clipping at high input levels.
	LOW	The audio signal will be output unchanged (0 dB gain).

**Note**

1. A possibility to copy from SCART 1 input to SCART 1 output is not implemented.

10.3.18 SCART 2 OUTPUT SELECT REGISTER

10.3.18.1 Description

This register is used to define both the signal source to be output at SCART 2 and the output channel selector mode.

10.3.18.2 Definition

**Table 45** Subaddress 21 (notes 1 and 2)

MSB						LSB	
B7	B6	B5	B4	B3	B2	B1	B0
X	SC2GAIN <sup>(3)</sup>	see Table 47		X	see Table 46		

**Notes**

1. X = don't care.
2. The default setting at power-up is 00000000.
3. See Table 48.

**Table 46** Signal source

B2	B1	B0	SIGNAL SOURCE
0	0	0	SCART 1 input
0	1	0	external input
0	1	1	mono input
1	0	0	DAC input

**Table 47** Bits B5 and B4

B5	B4	L OUTPUT	R OUTPUT
0	0	L input	R input
0	1	L input	L input
1	0	R input	R input
1	1	R input	L input



# Digital TV Sound Processor (DTVSP)

# TDA9875

**Table 48** Description of bit SC2GAIN (note 1)

NAME	HIGH/LOW	FUNCTION
SC2GAIN	HIGH	Activates the 3 dB gain stage at the SCART 2 output port. As any SCART input passes a 3 dB attenuator, this gain stage can be used to compensate that attenuation, resulting in a 0 dB insertion loss when copying from SCART 1 input to SCART 2 output. However, that gain must be used with great care, as it will cause signal clipping at high input levels.
	LOW	The audio signal will be output unchanged (0 dB gain).

**Note**

1. A possibility to copy from SCART 2 input to SCART 2 output is not implemented.

### 10.3.19 LINE OUTPUT SELECT REGISTER

#### 10.3.19.1 Description

By definition, the line output conveys the same signal as the Main (loudspeaker) channel, but in a non-processed form. This register is used to characterize the signal to be output at the line output and define the output channel selector mode.

#### 10.3.19.2 Definition

**Table 49** Subaddress 22 (note 1)

BIT	NAME	DESCRIPTION
7 (MSB)	X	don't care
6	LINGAIN	line output gain on/off; see Table 51
5		see Table 50
4		
3	X	don't care
2	X	don't care
1	X	don't care
0 (LSB)	LINSEL	select source for line output; see Table 51

**Note**

1. The default setting at power-up is 00000000.

**Table 50** Bits B5 and B4

B5	B4	L OUTPUT	R OUTPUT
0	0	L input	R input
0	1	L input	L input
1	0	R input	R input
1	1	R input	L input

## Digital TV Sound Processor (DTVSP)

TDA9875

**Table 51** Description of bits LINSEL and LINGAIN

NAME	HIGH/LOW	FUNCTION
LINSEL	HIGH	Specifies that a signal from an analog source is being processed in the Main channel. Analog signal sources comprise SCART 1 input, SCART 2 input, external input and mono input, i.e. any input to the ADC.
	LOW	Specifies that a signal from a digital source is being processed in the Main channel. Digital signal sources comprise FM, NICAM, I <sup>2</sup> S1 input and I <sup>2</sup> S2 input.
LINGAIN	HIGH	Activates the 3 dB gain stage at the line output port.
	LOW	The audio signal will be output unchanged (0 dB gain).

## 10.3.20 ADC OUTPUT SELECT REGISTER

## 10.3.20.1 Description

This register is used to define the signal source for the ADC. There is no output channel selector, because all digital signal sinks of the ADC have their own matrix. Instead, a level adjustment facility for the ADC output is provided.

## 10.3.20.2 Definition

**Table 52** Subaddress 23 (note 1)

MSB						LSB	
B7	B6	B5	B4	B3	B2	B1	B0
see Table 53			see Table 54				

**Note**

- The default setting at power-up is 00000000.

**Table 53** Signal source

B7	B6	B5	SIGNAL SOURCE
0	0	0	SCART 1 input
0	0	1	SCART 2 input
0	1	0	external input
0	1	1	mono input

**Table 54** Gain setting (notes 1 and 2)

B4	B3	B2	B1	B0	GAIN SETTING (dB)
0	1	1	1	1	+15
0	1	1	1	0	+14
0	1	1	0	1	+13
0	1	1	0	0	+12
0	1	0	1	1	+11
0	1	0	1	0	+10
0	1	0	0	1	+9
0	1	0	0	0	+8
0	0	1	1	1	+7

## Digital TV Sound Processor (DTVSP)

TDA9875

B4	B3	B2	B1	B0	GAIN SETTING (dB)
0	0	1	1	0	+6
0	0	1	0	1	+5
0	0	1	0	0	+4
0	0	0	1	1	+3
0	0	0	1	0	+2
0	0	0	0	1	+1
0	0	0	0	0	0
1	1	1	1	1	-1
1	1	1	1	0	-2
1	1	1	0	1	-3
1	1	1	0	0	-4
1	1	0	1	1	-5
1	1	0	1	0	-6
1	1	0	0	1	-7
1	1	0	0	0	-8
1	0	1	1	1	-9
1	0	1	1	0	-10
1	0	1	0	1	-11
1	0	1	0	0	-12
1	0	0	1	1	-13
1	0	0	1	0	-14
1	0	0	0	1	-15
1	0	0	0	0	mute

**Notes**

1. An input of the DAC output to the ADC is meaningless and, therefore, not implemented.
2. A full-scale input signal to the ADC results in an output level of -6 dB (full-scale). This occurs prior to any gain setting.

## 10.3.21 MAIN CHANNEL SELECT REGISTER

## 10.3.21.1 Description

This register is used to define both the signal source to be processed in the Main (loudspeaker) channel and the mode of the digital matrix for signal selection.

## 10.3.21.2 Definition

**Table 55** Subaddress 24 (notes 1 and 2)

MSB					LSB		
B7	B6	B5	B4	B3	B2	B1	B0
X	see Table 57			X	see Table 56		

**Notes**

1. X = don't care.
2. The default setting at power-up is 00000000.

Digital TV Sound Processor (DTVSP)

TDA9875

**Table 56** Signal source

B2	B1	B0	SIGNAL SOURCE
0	0	0	FM input
0	0	1	NICAM input
0	1	0	I <sup>2</sup> S1 input
0	1	1	I <sup>2</sup> S2 input
1	0	0	ADC input

**Table 57** Bits B6 to B4 (note 1)

B6	B5	B4	L OUTPUT	R OUTPUT
0	0	0	L input	R input
0	0	1	L input	L input
0	1	0	R input	R input
0	1	1	R input	L input
1	X	X	$\frac{L + R}{2}$	$\frac{L + R}{2}$

**Note**

- 1. X = don't care.

10.3.22 AUDIO EFFECTS REGISTER

10.3.22.1 Definition

**Table 58** Subaddress 25 (notes 1 and 2; see Table 62)

MSB							LSB
B7	B6	B5	B4	B3	B2	B1	B0
X	X	SPATIAL1 <sup>(3)</sup>	SPATIAL0 <sup>(3)</sup>	PSEUDO1 <sup>(4)</sup>	PSEUDO0 <sup>(4)</sup>	AVL1 <sup>(5)</sup>	AVL0 <sup>(5)</sup>

**Notes**

- 1. X = don't care.
- 2. The default setting at power-up is 00000000.
- 3. See Table 61.
- 4. See Table 60.
- 5. See Table 59.

**Table 59** AVL control mode

B1	B0	AVL MODE
0	0	off/reset
0	1	short decay
1	0	medium decay
1	1	long decay

## Digital TV Sound Processor (DTVSP)

TDA9875

**Table 60** Pseudo control setting

B3	B2	PSEUDO SETTING (Hz)
0	0	off
0	1	300
1	0	200
1	1	150

**Table 61** Spatial control setting

B5	B4	SPATIAL SETTING (%)
0	0	off
0	1	30
1	0	40
1	1	52

**Table 62** Description of Table 58 (notes 1, 2 and 3)

NAME	FUNCTION
AVL0, AVL1	These bits set the mode of operation of the automatic volume level control function at the entrance to the Main (loudspeaker) channel.
PSEUDO0, PSEUDO1	These bits set the amount of the effect function (pseudo stereo) for mono signals in the Main channel. This function should be activated only in accordance with the result of the sound mode identification.
SPATIAL0, SPATIAL1	These bits set the amount of the effect function (stereo base width expansion) for stereo signals in the Main channel. This function should be activated only in accordance with the result of the sound mode identification.

**Notes**

- Switching the AVL off will reset the associated hardware to a defined state.
- When the signal source for the Main channel is changed while the AVL is on, the AVL needs to be reset in order to avoid excessive settling times. This can be achieved by switching the AVL off and on again.
- The pseudo stereo function is based on an all-pass filter. A 90 degrees phase shift occurs at the frequencies stated in Table 60. There is a gain of 3 dB in the audio channel containing the filter.

## 10.3.23 VOLUME CONTROL REGISTERS (MAIN)

## 10.3.23.1 Description

These two registers control the volume setting of the Main (loudspeaker) channel. The register at subaddress 26 applies to the left channel signal, while the register at subaddress 27 applies to the right channel signal.

Balance control is exercised by offsetting the left and right channel volume settings.

## Digital TV Sound Processor (DTVSP)

TDA9875

## 10.3.23.2 Definition

Table 63 Subaddresses 26 and 27

MSB							LSB	VOLUME SETTING (dB)
B7	B6	B5	B4	B3	B2	B1	B0	
0	0	0	1	1	0	0	0	+24
0	0	0	1	0	1	1	1	+23
0	0	0	1	0	1	1	0	+22
0	0	0	1	0	1	0	1	+21
0	0	0	1	0	1	0	0	+20
0	0	0	1	0	0	1	1	+19
0	0	0	1	0	0	1	0	+18
0	0	0	1	0	0	0	1	+17
0	0	0	1	0	0	0	0	+16
0	0	0	0	1	1	1	1	+15
0	0	0	0	1	1	1	0	+14
0	0	0	0	1	1	0	1	+13
0	0	0	0	1	1	0	0	+12
0	0	0	0	1	0	1	1	+11
0	0	0	0	1	0	1	0	+10
0	0	0	0	1	0	0	1	+9
0	0	0	0	1	0	0	0	+8
0	0	0	0	0	1	1	1	+7
0	0	0	0	0	1	1	0	+6
0	0	0	0	0	1	0	1	+5
0	0	0	0	0	1	0	0	+4
0	0	0	0	0	0	1	1	+3
0	0	0	0	0	0	1	0	+2
0	0	0	0	0	0	0	1	+1
0	0	0	0	0	0	0	0	0
1	1	1	1	1	1	1	1	-1
1	1	1	1	1	1	1	0	-2
1	1	1	1	1	1	0	1	-3
1	1	1	1	1	1	0	0	-4
1	1	1	1	1	0	1	1	-5
1	1	1	1	1	0	1	0	-6
1	1	1	1	1	0	0	1	-7
1	1	1	1	1	0	0	0	-8
1	1	1	1	0	1	1	1	-9
1	1	1	1	0	1	1	0	-10
1	1	1	1	0	1	0	1	-11
1	1	1	1	0	1	0	0	-12

## Digital TV Sound Processor (DTVSP)

TDA9875

MSB							LSB	VOLUME SETTING (dB)
B7	B6	B5	B4	B3	B2	B1	B0	
1	1	1	1	0	0	1	1	-13
1	1	1	1	0	0	1	0	-14
1	1	1	1	0	0	0	1	-15
1	1	1	1	0	0	0	0	-16
1	1	1	0	1	1	1	1	-17
1	1	1	0	1	1	1	0	-18
1	1	1	0	1	1	0	1	-19
1	1	1	0	1	1	0	0	-20
1	1	1	0	1	0	1	1	-21
1	1	1	0	1	0	1	0	-22
1	1	1	0	1	0	0	1	-23
1	1	1	0	1	0	0	0	-24
1	1	1	0	0	1	1	1	-25
1	1	1	0	0	1	1	0	-26
1	1	1	0	0	1	0	1	-27
1	1	1	0	0	1	0	0	-28
1	1	1	0	0	0	1	1	-29
1	1	1	0	0	0	1	0	-30
1	1	1	0	0	0	0	1	-31
1	1	1	0	0	0	0	0	-32
1	1	0	1	1	1	1	1	-33
1	1	0	1	1	1	1	0	-34
1	1	0	1	1	1	0	1	-35
1	1	0	1	1	1	0	0	-36
1	1	0	1	1	0	1	1	-37
1	1	0	1	1	0	1	0	-38
1	1	0	1	1	0	0	1	-39
1	1	0	1	1	0	0	0	-40
1	1	0	1	0	1	1	1	-41
1	1	0	1	0	1	1	0	-42
1	1	0	1	0	1	0	1	-43
1	1	0	1	0	1	0	0	-44
1	1	0	1	0	0	1	1	-45
1	1	0	1	0	0	1	0	-46
1	1	0	1	0	0	0	1	-47
1	1	0	1	0	0	0	0	-48
1	1	0	0	1	1	1	1	-49
1	1	0	0	1	1	1	0	-50
1	1	0	0	1	1	0	1	-51

## Digital TV Sound Processor (DTVSP)

TDA9875

MSB							LSB		VOLUME SETTING (dB)
B7	B6	B5	B4	B3	B2	B1	B0		
1	1	0	0	1	1	0	0	-52	
1	1	0	0	1	0	1	1	-53	
1	1	0	0	1	0	1	0	-54	
1	1	0	0	1	0	0	1	-55	
1	1	0	0	1	0	0	0	-56	
1	1	0	0	0	1	1	1	-57	
1	1	0	0	0	1	1	0	-58	
1	1	0	0	0	1	0	1	-59	
1	1	0	0	0	1	0	0	-60	
1	1	0	0	0	0	1	1	-61	
1	1	0	0	0	0	1	0	-62	
1	1	0	0	0	0	0	1	-63	
1	1	0	0	0	0	0	0	-64	
1	0	1	1	1	1	1	1	-65	
1	0	1	1	1	1	1	0	-66	
1	0	1	1	1	1	0	1	-67	
1	0	1	1	1	1	0	0	-68	
1	0	1	1	1	0	1	1	-69	
1	0	1	1	1	0	1	0	-70	
1	0	1	1	1	0	0	1	-71	
1	0	1	1	1	0	0	0	-72	
1	0	1	1	0	1	1	1	-73	
1	0	1	1	0	1	1	0	-74	
1	0	1	1	0	1	0	1	-75	
1	0	1	1	0	1	0	0	-76	
1	0	1	1	0	0	1	1	-77	
1	0	1	1	0	0	1	0	-78	
1	0	1	1	0	0	0	1	-79	
1	0	1	1	0	0	0	0	-80	
1	0	1	0	1	1	1	1	-81	
1	0	1	0	1	1	1	0	-82	
1	0	1	0	1	1	0	1	-83	
1	0	1	0	1	1	0	0	mute (note 1)	

**Note**

1. The default setting at power-up is 10101100.



## Digital TV Sound Processor (DTVSP)

TDA9875

## 10.3.24 CONTOUR CONTROL REGISTER

## 10.3.24.1 Description

This register is used to apply the contour or loudness function (physiological volume control) to the left and right signal channels of the Main channel by means of an extra bass boost. The gain setting must be chosen in accordance with the volume control setting for the Main channel. For example, the contour gain could be incremented for every 5 dB, or so, of decrease of the volume setting. The 0 dB contour setting is equal to contour off.

## 10.3.24.2 Definition

Table 64 Subaddress 28 (note 1)

MSB							LSB	CONTOUR GAIN (dB)
B7	B6	B5	B4	B3	B2	B1	B0	
X	X	X	1	0	0	1	0	18
X	X	X	1	0	0	0	1	17
X	X	X	1	0	0	0	0	16
X	X	X	0	1	1	1	1	15
X	X	X	0	1	1	1	0	14
X	X	X	0	1	1	0	1	13
X	X	X	0	1	1	0	0	12
X	X	X	0	1	0	1	1	11
X	X	X	0	1	0	1	0	10
X	X	X	0	1	0	0	1	9
X	X	X	0	1	0	0	0	8
X	X	X	0	0	1	1	1	7
X	X	X	0	0	1	1	0	6
X	X	X	0	0	1	0	1	5
X	X	X	0	0	1	0	0	4
X	X	X	0	0	0	1	1	3
X	X	X	0	0	0	1	0	2
X	X	X	0	0	0	0	1	1
X	X	X	0	0	0	0	0	0 (note 2)

## Notes

1. X = don't care.
2. The default setting at power-up is 00000000.

## 10.3.25 BASS CONTROL REGISTER (MAIN)

## 10.3.25.1 Description

This register is used to apply bass control to the left and right signal channels of the Main channel.

## Digital TV Sound Processor (DTVSP)

TDA9875

## 10.3.25.2 Definition

Table 65 Subaddress 29 (note 1)

MSB							LSB		BASS SETTING (dB)
B7	B6	B5	B4	B3	B2	B1	B0		
X	X	X	0	1	1	1	1	+15	
X	X	X	0	1	1	1	0	+14	
X	X	X	0	1	1	0	1	+13	
X	X	X	0	1	1	0	0	+12	
X	X	X	0	1	0	1	1	+11	
X	X	X	0	1	0	1	0	+10	
X	X	X	0	1	0	0	1	+9	
X	X	X	0	1	0	0	0	+8	
X	X	X	0	0	1	1	1	+7	
X	X	X	0	0	1	1	0	+6	
X	X	X	0	0	1	0	1	+5	
X	X	X	0	0	1	0	0	+4	
X	X	X	0	0	0	1	1	+3	
X	X	X	0	0	0	1	0	+2	
X	X	X	0	0	0	0	1	+1	
X	X	X	0	0	0	0	0	0 (note 2)	
X	X	X	1	1	1	1	1	-1	
X	X	X	1	1	1	1	0	-2	
X	X	X	1	1	1	0	1	-3	
X	X	X	1	1	1	0	0	-4	
X	X	X	1	1	0	1	1	-5	
X	X	X	1	1	0	1	0	-6	
X	X	X	1	1	0	0	1	-7	
X	X	X	1	1	0	0	0	-8	
X	X	X	1	0	1	1	1	-9	
X	X	X	1	0	1	1	0	-10	
X	X	X	1	0	1	0	1	-11	
X	X	X	1	0	1	0	0	-12	

## Notes

1. X = don't care.
2. The default setting at power-up is 00000000.

## Digital TV Sound Processor (DTVSP)

TDA9875

## 10.3.26 TREBLE CONTROL REGISTER (MAIN)

## 10.3.26.1 Description

This register is used to apply treble control to the left and right signal channels of the Main channel.

## 10.3.26.2 Definition

**Table 66** Subaddress 30 (note 1)

MSB							LSB	TREBLE SETTING (dB)
B7	B6	B5	B4	B3	B2	B1	B0	
X	X	X	0	1	1	0	0	+12
X	X	X	0	1	0	1	1	+11
X	X	X	0	1	0	1	0	+10
X	X	X	0	1	0	0	1	+9
X	X	X	0	1	0	0	0	+8
X	X	X	0	0	1	1	1	+7
X	X	X	0	0	1	1	0	+6
X	X	X	0	0	1	0	1	+5
X	X	X	0	0	1	0	0	+4
X	X	X	0	0	0	1	1	+3
X	X	X	0	0	0	1	0	+2
X	X	X	0	0	0	0	1	+1
X	X	X	0	0	0	0	0	0 (note 2)
X	X	X	1	1	1	1	1	-1
X	X	X	1	1	1	1	0	-2
X	X	X	1	1	1	0	1	-3
X	X	X	1	1	1	0	0	-4
X	X	X	1	1	0	1	1	-5
X	X	X	1	1	0	1	0	-6
X	X	X	1	1	0	0	1	-7
X	X	X	1	1	0	0	0	-8
X	X	X	1	0	1	1	1	-9
X	X	X	1	0	1	1	0	-10
X	X	X	1	0	1	0	1	-11
X	X	X	1	0	1	0	0	-12

**Notes**

1. X = don't care.
2. The default setting at power-up is 00000000.

# Digital TV Sound Processor (DTVSP)

# TDA9875

## 10.3.27 AUXILIARY CHANNEL SELECT REGISTER

### 10.3.27.1 Description

This register is used to define both the signal source to be processed in the Auxiliary (headphone) channel and the mode of the digital matrix for signal selection.

### 10.3.27.2 Definition

**Table 67** Subaddress 31 (notes 1 and 2)

MSB					LSB		
B7	B6	B5	B4	B3	B2	B1	B0
X	see Table 69			X	see Table 68		

#### Notes

1. X = don't care.
2. The default setting at power-up is 00000000.

**Table 68** Signal source

B2	B1	B0	SIGNAL SOURCE
0	0	0	FM input
0	0	1	NICAM input
0	1	0	I <sup>2</sup> S1 input
0	1	1	I <sup>2</sup> S2 input
1	0	0	ADC input
1	0	1	AVL input

**Table 69** Bits B6 to B4 (note 1)

B6	B5	B4	L OUTPUT	R OUTPUT
0	0	0	L input	R input
0	0	1	L input	L input
0	1	0	R input	R input
0	1	1	R input	L input
1	X	X	$\frac{L + R}{2}$	$\frac{L + R}{2}$

#### Note

1. X = don't care.

## Digital TV Sound Processor (DTVSP)

TDA9875

## 10.3.28 VOLUME CONTROL REGISTERS (AUXILIARY)

## 10.3.28.1 Description

These two registers control the volume setting of the Auxiliary (headphone) channel. The register at subaddress 32 applies to the left channel signal, while the register at subaddress 33 applies to the right channel signal.

Balance control is exercised by offsetting the left and right channel volume settings.

## 10.3.28.2 Definition

Table 70 Subaddresses 32 and 33

MSB				LSB				VOLUME SETTING (dB)
B7	B6	B5	B4	B3	B2	B1	B0	
0	0	0	1	1	0	0	0	+24
0	0	0	1	0	1	1	1	+23
0	0	0	1	0	1	1	0	+22
0	0	0	1	0	1	0	1	+21
0	0	0	1	0	1	0	0	+20
0	0	0	1	0	0	1	1	+19
0	0	0	1	0	0	1	0	+18
0	0	0	1	0	0	0	1	+17
0	0	0	1	0	0	0	0	+16
0	0	0	0	1	1	1	1	+15
0	0	0	0	1	1	1	0	+14
0	0	0	0	1	1	0	1	+13
0	0	0	0	1	1	0	0	+12
0	0	0	0	1	0	1	1	+11
0	0	0	0	1	0	1	0	+10
0	0	0	0	1	0	0	1	+9
0	0	0	0	1	0	0	0	+8
0	0	0	0	0	1	1	1	+7
0	0	0	0	0	1	1	0	+6
0	0	0	0	0	1	0	1	+5
0	0	0	0	0	1	0	0	+4
0	0	0	0	0	0	1	1	+3
0	0	0	0	0	0	1	0	+2
0	0	0	0	0	0	0	1	+1
0	0	0	0	0	0	0	0	0
1	1	1	1	1	1	1	1	-1
1	1	1	1	1	1	1	0	-2
1	1	1	1	1	1	0	1	-3
1	1	1	1	1	1	0	0	-4
1	1	1	1	1	0	1	1	-5
1	1	1	1	1	0	1	0	-6
1	1	1	1	1	0	0	1	-7

## Digital TV Sound Processor (DTVSP)

TDA9875

MSB							LSB		VOLUME SETTING (dB)
B7	B6	B5	B4	B3	B2	B1	B0		
1	1	1	1	1	0	0	0	-8	
1	1	1	1	0	1	1	1	-9	
1	1	1	1	0	1	1	0	-10	
1	1	1	1	0	1	0	1	-11	
1	1	1	1	0	1	0	0	-12	
1	1	1	1	0	0	1	1	-13	
1	1	1	1	0	0	1	0	-14	
1	1	1	1	0	0	0	1	-15	
1	1	1	1	0	0	0	0	-16	
1	1	1	0	1	1	1	1	-17	
1	1	1	0	1	1	1	0	-18	
1	1	1	0	1	1	0	1	-19	
1	1	1	0	1	1	0	0	-20	
1	1	1	0	1	0	1	1	-21	
1	1	1	0	1	0	1	0	-22	
1	1	1	0	1	0	0	1	-23	
1	1	1	0	1	0	0	0	-24	
1	1	1	0	0	1	1	1	-25	
1	1	1	0	0	1	1	0	-26	
1	1	1	0	0	1	0	1	-27	
1	1	1	0	0	1	0	0	-28	
1	1	1	0	0	0	1	1	-29	
1	1	1	0	0	0	1	0	-30	
1	1	1	0	0	0	0	1	-31	
1	1	1	0	0	0	0	0	-32	
1	1	0	1	1	1	1	1	-33	
1	1	0	1	1	1	1	0	-34	
1	1	0	1	1	1	0	1	-35	
1	1	0	1	1	1	0	0	-36	
1	1	0	1	1	0	1	1	-37	
1	1	0	1	1	0	1	0	-38	
1	1	0	1	1	0	0	1	-39	
1	1	0	1	1	0	0	0	-40	
1	1	0	1	0	1	1	1	-41	
1	1	0	1	0	1	1	0	-42	
1	1	0	1	0	1	0	1	-43	
1	1	0	1	0	1	0	0	-44	
1	1	0	1	0	0	1	1	-45	
1	1	0	1	0	0	1	0	-46	
1	1	0	1	0	0	0	1	-47	
1	1	0	1	0	0	0	0	-48	

## Digital TV Sound Processor (DTVSP)

TDA9875

MSB				LSB				VOLUME SETTING (dB)
B7	B6	B5	B4	B3	B2	B1	B0	
1	1	0	0	1	1	1	1	-49
1	1	0	0	1	1	1	0	-50
1	1	0	0	1	1	0	1	-51
1	1	0	0	1	1	0	0	-52
1	1	0	0	1	0	1	1	-53
1	1	0	0	1	0	1	0	-54
1	1	0	0	1	0	0	1	-55
1	1	0	0	1	0	0	0	-56
1	1	0	0	0	1	1	1	-57
1	1	0	0	0	1	1	0	-58
1	1	0	0	0	1	0	1	-59
1	1	0	0	0	1	0	0	-60
1	1	0	0	0	0	1	1	-61
1	1	0	0	0	0	1	0	-62
1	1	0	0	0	0	0	1	-63
1	1	0	0	0	0	0	0	-64
1	0	1	1	1	1	1	1	-65
1	0	1	1	1	1	1	0	-66
1	0	1	1	1	1	0	1	-67
1	0	1	1	1	1	0	0	-68
1	0	1	1	1	0	1	1	-69
1	0	1	1	1	0	1	0	-70
1	0	1	1	1	0	0	1	-71
1	0	1	1	1	0	0	0	-72
1	0	1	1	0	1	1	1	-73
1	0	1	1	0	1	1	0	-74
1	0	1	1	0	1	0	1	-75
1	0	1	1	0	1	0	0	-76
1	0	1	1	0	0	1	1	-77
1	0	1	1	0	0	1	0	-78
1	0	1	1	0	0	0	1	-79
1	0	1	1	0	0	0	0	-80
1	0	1	0	1	1	1	1	-81
1	0	1	0	1	1	1	0	-82
1	0	1	0	1	1	0	1	-83
1	0	1	0	1	1	0	0	mute (note 1)

**Note**

1. The default setting at power-up is 10101100.

## Digital TV Sound Processor (DTVSP)

## TDA9875

## 10.3.29 BASS CONTROL REGISTER (AUXILIARY)

## 10.3.29.1 Description

This register is used to apply bass control to the left and right signal channels of the Auxiliary channel.

## 10.3.29.2 Definition

Table 71 Subaddress 34 (note 1)

MSB							LSB		BASS SETTING (dB)
B7	B6	B5	B4	B3	B2	B1	B0		
X	X	X	0	1	1	1	1	+15	
X	X	X	0	1	1	1	0	+14	
X	X	X	0	1	1	0	1	+13	
X	X	X	0	1	1	0	0	+12	
X	X	X	0	1	0	1	1	+11	
X	X	X	0	1	0	1	0	+10	
X	X	X	0	1	0	0	1	+9	
X	X	X	0	1	0	0	0	+8	
X	X	X	0	0	1	1	1	+7	
X	X	X	0	0	1	1	0	+6	
X	X	X	0	0	1	0	1	+5	
X	X	X	0	0	1	0	0	+4	
X	X	X	0	0	0	1	1	+3	
X	X	X	0	0	0	1	0	+2	
X	X	X	0	0	0	0	1	+1	
X	X	X	0	0	0	0	0	0 (note 2)	
X	X	X	1	1	1	1	1	-1	
X	X	X	1	1	1	1	0	-2	
X	X	X	1	1	1	0	1	-3	
X	X	X	1	1	1	0	0	-4	
X	X	X	1	1	0	1	1	-5	
X	X	X	1	1	0	1	0	-6	
X	X	X	1	1	0	0	1	-7	
X	X	X	1	1	0	0	0	-8	
X	X	X	1	0	1	1	1	-9	
X	X	X	1	0	1	1	0	-10	
X	X	X	1	0	1	0	1	-11	
X	X	X	1	0	1	0	0	-12	

## Notes

1. X = don't care.
2. The default setting at power-up is 00000000.



## Digital TV Sound Processor (DTVSP)

TDA9875

## 10.3.30 TREBLE CONTROL REGISTER (AUXILIARY)

## 10.3.30.1 Description

This register is used to apply treble control to the left and right signal channels of the Auxiliary channel.

## 10.3.30.2 Definition

Table 72 Subaddress 35 (note 1)

MSB							LSB		TREBLE SETTING (dB)
B7	B6	B5	B4	B3	B2	B1	B0		
X	X	X	0	1	1	0	0	+12	
X	X	X	0	1	0	1	1	+11	
X	X	X	0	1	0	1	0	+10	
X	X	X	0	1	0	0	1	+9	
X	X	X	0	1	0	0	0	+8	
X	X	X	0	0	1	1	1	+7	
X	X	X	0	0	1	1	0	+6	
X	X	X	0	0	1	0	1	+5	
X	X	X	0	0	1	0	0	+4	
X	X	X	0	0	0	1	1	+3	
X	X	X	0	0	0	1	0	+2	
X	X	X	0	0	0	0	1	+1	
X	X	X	0	0	0	0	0	0 (note 2)	
X	X	X	1	1	1	1	1	-1	
X	X	X	1	1	1	1	0	-2	
X	X	X	1	1	1	0	1	-3	
X	X	X	1	1	1	0	0	-4	
X	X	X	1	1	0	1	1	-5	
X	X	X	1	1	0	1	0	-6	
X	X	X	1	1	0	0	1	-7	
X	X	X	1	1	0	0	0	-8	
X	X	X	1	0	1	1	1	-9	
X	X	X	1	0	1	1	0	-10	
X	X	X	1	0	1	0	1	-11	
X	X	X	1	0	1	0	0	-12	

## Notes

1. X = don't care.
2. The default setting at power-up is 00000000.

# Digital TV Sound Processor (DTVSP)

# TDA9875

## 10.3.31 FEATURE INTERFACE CONFIGURATION REGISTER

### 10.3.31.1 Definition

**Table 73** Subaddress 36 (notes 1 and 2)

MSB							LSB	
B7	B6	B5	B4	B3	B2	B1	B0	
X	X	X	SYSCL1 <sup>(3)</sup>	SYSCL0 <sup>(3)</sup>	SYSOUT <sup>(4)</sup>	I <sup>2</sup> SFORM <sup>(5)</sup>	I <sup>2</sup> SOUT <sup>(6)</sup>	

**Notes**

1. X = don't care.
2. The default setting at power-up is 00000000.
3. System clock frequency select; see Table 74.
4. System clock output on/off; see Table 75.
5. Serial output format; see Table 75.
6. I<sup>2</sup>S-bus outputs on/off; see Table 75.

**Table 74** System clock frequency select

B4	B3	SYSCLK OUTPUT	FREQUENCY (MHz)
0	0	256f <sub>s</sub>	8.192
0	1	384f <sub>s</sub>	12.288
1	0	512f <sub>s</sub>	16.384
1	1	768f <sub>s</sub>	24.576

**Table 75** Description of Table 73

NAME	HIGH/LOW	FUNCTION
I <sup>2</sup> SOUT	HIGH	Enables the output of serial audio data (2 pins) plus serial bit clock and word select in a format determined by the I <sup>2</sup> SFORM bit. The TDA9875 is then an I <sup>2</sup> S-bus master.
	LOW	the outputs mentioned will be 3-stated, thereby improving the EMC performance
I <sup>2</sup> SFORM	HIGH	an MSB-aligned, MSB-first output format is selected, i.e. a level change at the word select pin indicates the beginning of a new audio sample
	LOW	the standard I <sup>2</sup> S-bus output format is selected
SYSOUT	HIGH	enables the output of a system (or master) clock signal at pin SYSCLK
	LOW	the output will be off, thereby improving the EMC performance

# Digital TV Sound Processor (DTVSP)

# TDA9875

## 10.3.32 I<sup>2</sup>S1 OUTPUT SELECT REGISTER

### 10.3.32.1 Description

This register is used to define both the signal source to be output at I<sup>2</sup>S1 and the mode of the digital matrix for signal selection.

### 10.3.32.2 Definition

**Table 76** Subaddress 37 (notes 1 and 2)

MSB				LSB			
B7	B6	B5	B4	B3	B2	B1	B0
X	see Table 78			X	see Table 77		

#### Notes

1. X = don't care.
2. The default setting at power-up is 00000000.

**Table 77** Signal source (note 1)

B2	B1	B0	SIGNAL SOURCE
0	0	0	FM output
0	0	1	NICAM output
0	1	0	I <sup>2</sup> S1 input
0	1	1	I <sup>2</sup> S2 input
1	0	0	ADC output
1	0	1	AVL output
1	1	0	Auxiliary output
1	1	1	Main output

#### Note

1. The Main and Auxiliary channel outputs will not contain the beeper signal.

**Table 78** Bits B6 to B4 (note 1)

B6	B5	B4	L OUTPUT	R OUTPUT
0	0	0	L input	R input
0	0	1	L input	L input
0	1	0	R input	R input
0	1	1	R input	L input
1	X	X	$\frac{L + R}{2}$	$\frac{L + R}{2}$

#### Note

1. X = don't care.

## Digital TV Sound Processor (DTVSP)

TDA9875

10.3.33 I<sup>2</sup>S1 INPUT LEVEL ADJUST REGISTER

## 10.3.33.1 Description

This register is used to adjust the input level at the I<sup>2</sup>S1 interface. Left and right signal channel are treated identically.

## 10.3.33.2 Definition

Table 79 Subaddress 38 (note 1)

MSB							LSB		GAIN SETTING (dB)
B7	B6	B5	B4	B3	B2	B1	B0		
X	X	X	0	1	1	1	1	+15	
X	X	X	0	1	1	1	0	+14	
X	X	X	0	1	1	0	1	+13	
X	X	X	0	1	1	0	0	+12	
X	X	X	0	1	0	1	1	+11	
X	X	X	0	1	0	1	0	+10	
X	X	X	0	1	0	0	1	+9	
X	X	X	0	1	0	0	0	+8	
X	X	X	0	0	1	1	1	+7	
X	X	X	0	0	1	1	0	+6	
X	X	X	0	0	1	0	1	+5	
X	X	X	0	0	1	0	0	+4	
X	X	X	0	0	0	1	1	+3	
X	X	X	0	0	0	1	0	+2	
X	X	X	0	0	0	0	1	+1	
X	X	X	0	0	0	0	0	0 (note 2)	
X	X	X	1	1	1	1	1	-1	
X	X	X	1	1	1	1	0	-2	
X	X	X	1	1	1	0	1	-3	
X	X	X	1	1	1	0	0	-4	
X	X	X	1	1	0	1	1	-5	
X	X	X	1	1	0	1	0	-6	
X	X	X	1	1	0	0	1	-7	
X	X	X	1	1	0	0	0	-8	
X	X	X	1	0	1	1	1	-9	
X	X	X	1	0	1	1	0	-10	
X	X	X	1	0	1	0	1	-11	
X	X	X	1	0	1	0	0	-12	
X	X	X	1	0	0	1	1	-13	
X	X	X	1	0	0	1	0	-14	
X	X	X	1	0	0	0	1	-15	
X	X	X	1	0	0	0	0	mute	

## Notes

1. X = don't care.
2. The default setting at power-up is 00000000.

## Digital TV Sound Processor (DTVSP)

TDA9875

10.3.34 I<sup>2</sup>S1 OUTPUT LEVEL ADJUST REGISTER

## 10.3.34.1 Description

This register is used to adjust the output level at the I<sup>2</sup>S1 interface. Left and right signal channel are treated identically.

## 10.3.34.2 Definition

Table 80 Subaddress 39 (note 1)

MSB							LSB		GAIN SETTING (dB)
B7	B6	B5	B4	B3	B2	B1	B0		
X	X	X	0	1	1	1	1	+15	
X	X	X	0	1	1	1	0	+14	
X	X	X	0	1	1	0	1	+13	
X	X	X	0	1	1	0	0	+12	
X	X	X	0	1	0	1	1	+11	
X	X	X	0	1	0	1	0	+10	
X	X	X	0	1	0	0	1	+9	
X	X	X	0	1	0	0	0	+8	
X	X	X	0	0	1	1	1	+7	
X	X	X	0	0	1	1	0	+6	
X	X	X	0	0	1	0	1	+5	
X	X	X	0	0	1	0	0	+4	
X	X	X	0	0	0	1	1	+3	
X	X	X	0	0	0	1	0	+2	
X	X	X	0	0	0	0	1	+1	
X	X	X	0	0	0	0	0	0 (note 2)	
X	X	X	1	1	1	1	1	-1	
X	X	X	1	1	1	1	0	-2	
X	X	X	1	1	1	0	1	-3	
X	X	X	1	1	1	0	0	-4	
X	X	X	1	1	0	1	1	-5	
X	X	X	1	1	0	1	0	-6	
X	X	X	1	1	0	0	1	-7	
X	X	X	1	1	0	0	0	-8	
X	X	X	1	0	1	1	1	-9	
X	X	X	1	0	1	1	0	-10	
X	X	X	1	0	1	0	1	-11	
X	X	X	1	0	1	0	0	-12	
X	X	X	1	0	0	1	1	-13	
X	X	X	1	0	0	1	0	-14	
X	X	X	1	0	0	0	1	-15	
X	X	X	1	0	0	0	0	mute	

## Notes

1. X = don't care.
2. The default setting at power-up is 00000000.

## Digital TV Sound Processor (DTVSP)

TDA9875

10.3.35 I<sup>2</sup>S2 OUTPUT SELECT REGISTER

## 10.3.35.1 Description

This register is used to define both the signal source to be output at I<sup>2</sup>S2 and the mode of the digital matrix for signal selection.

## 10.3.35.2 Definition

**Table 81** Subaddress 40 (notes 1 and 2)

MSB					LSB		
B7	B6	B5	B4	B3	B2	B1	B0
X	see Table 83			X	see Table 82		

**Notes**

1. X = don't care.
2. The default setting at power-up is 00000000.

**Table 82** Signal source (note 1)

B2	B1	B0	SIGNAL SOURCE
0	0	0	FM output
0	0	1	NICAM output
0	1	0	I <sup>2</sup> S1 input
0	1	1	I <sup>2</sup> S2 input
1	0	0	ADC output
1	0	1	AVL output
1	1	0	Auxiliary output
1	1	1	Main output

**Note**

1. The Main and Auxiliary channel outputs will not contain the beeper signal.

**Table 83** Bits B6 to B4 (note 1)

B6	B5	B4	L OUTPUT	R OUTPUT
0	0	0	L input	R input
0	0	1	L input	L input
0	1	0	R input	R input
0	1	1	R input	L input
1	X	X	$\frac{L + R}{2}$	$\frac{L + R}{2}$

**Note**

1. X = don't care.

## Digital TV Sound Processor (DTVSP)

TDA9875

10.3.36 I<sup>2</sup>S2 INPUT LEVEL ADJUST REGISTER

## 10.3.36.1 Description

This register is used to adjust the input level at the I<sup>2</sup>S2 interface. Left and right signal channel are treated identically.

## 10.3.36.2 Definition

Table 84 Subaddress 41 (note 1)

MSB							LSB		GAIN SETTING (dB)
B7	B6	B5	B4	B3	B2	B1	B0		
X	X	X	0	1	1	1	1	+15	
X	X	X	0	1	1	1	0	+14	
X	X	X	0	1	1	0	1	+13	
X	X	X	0	1	1	0	0	+12	
X	X	X	0	1	0	1	1	+11	
X	X	X	0	1	0	1	0	+10	
X	X	X	0	1	0	0	1	+9	
X	X	X	0	1	0	0	0	+8	
X	X	X	0	0	1	1	1	+7	
X	X	X	0	0	1	1	0	+6	
X	X	X	0	0	1	0	1	+5	
X	X	X	0	0	1	0	0	+4	
X	X	X	0	0	0	1	1	+3	
X	X	X	0	0	0	1	0	+2	
X	X	X	0	0	0	0	1	+1	
X	X	X	0	0	0	0	0	0 (note 2)	
X	X	X	1	1	1	1	1	-1	
X	X	X	1	1	1	1	0	-2	
X	X	X	1	1	1	0	1	-3	
X	X	X	1	1	1	0	0	-4	
X	X	X	1	1	0	1	1	-5	
X	X	X	1	1	0	1	0	-6	
X	X	X	1	1	0	0	1	-7	
X	X	X	1	1	0	0	0	-8	
X	X	X	1	0	1	1	1	-9	
X	X	X	1	0	1	1	0	-10	
X	X	X	1	0	1	0	1	-11	
X	X	X	1	0	1	0	0	-12	
X	X	X	1	0	0	1	1	-13	
X	X	X	1	0	0	1	0	-14	
X	X	X	1	0	0	0	1	-15	
X	X	X	1	0	0	0	0	mute	

## Notes

1. X = don't care.
2. The default setting at power-up is 00000000.

## Digital TV Sound Processor (DTVSP)

TDA9875

10.3.37 I<sup>2</sup>S2 OUTPUT LEVEL ADJUST REGISTER

## 10.3.37.1 Description

This register is used to adjust the output level at the I<sup>2</sup>S2 interface. Left and right signal channel are treated identically.

## 10.3.37.2 Definition

Table 85 Subaddress 42 (note 1)

MSB							LSB		GAIN SETTING (dB)
B7	B6	B5	B4	B3	B2	B1	B0		
X	X	X	0	1	1	1	1	+15	
X	X	X	0	1	1	1	0	+14	
X	X	X	0	1	1	0	1	+13	
X	X	X	0	1	1	0	0	+12	
X	X	X	0	1	0	1	1	+11	
X	X	X	0	1	0	1	0	+10	
X	X	X	0	1	0	0	1	+9	
X	X	X	0	1	0	0	0	+8	
X	X	X	0	0	1	1	1	+7	
X	X	X	0	0	1	1	0	+6	
X	X	X	0	0	1	0	1	+5	
X	X	X	0	0	1	0	0	+4	
X	X	X	0	0	0	1	1	+3	
X	X	X	0	0	0	1	0	+2	
X	X	X	0	0	0	0	1	+1	
X	X	X	0	0	0	0	0	0 (note 2)	
X	X	X	1	1	1	1	1	-1	
X	X	X	1	1	1	1	0	-2	
X	X	X	1	1	1	0	1	-3	
X	X	X	1	1	1	0	0	-4	
X	X	X	1	1	0	1	1	-5	
X	X	X	1	1	0	1	0	-6	
X	X	X	1	1	0	0	1	-7	
X	X	X	1	1	0	0	0	-8	
X	X	X	1	0	1	1	1	-9	
X	X	X	1	0	1	1	0	-10	
X	X	X	1	0	1	0	1	-11	
X	X	X	1	0	1	0	0	-12	
X	X	X	1	0	0	1	1	-13	
X	X	X	1	0	0	1	0	-14	
X	X	X	1	0	0	0	1	-15	
X	X	X	1	0	0	0	0	mute	

## Notes

1. X = don't care.
2. The default setting at power-up is 00000000.



## Digital TV Sound Processor (DTVSP)

TDA9875

## 10.3.38 BEEPER FREQUENCY CONTROL REGISTER

## 10.3.38.1 Description

This register is used to select from sample beeper oscillator frequencies. The beeper output signal is added to the Main and Auxiliary channel output DAC.

Due to the frequency response of the audio DACs upsampling filters, the 25 kHz beep is approximately 5 dB louder than the 390 Hz beep.

## 10.3.38.2 Definition

Table 86 Subaddress 43 (notes 1 and 2)

MSB							LSB		GENERATED FREQUENCY (Hz)
B7	B6	B5	B4	B3	B2	B1	B0		
X	X	X	X	X	1	1	1	25000	
X	X	X	X	X	1	1	0	7040	
X	X	X	X	X	1	0	1	3580	
X	X	X	X	X	1	0	0	1770	
X	X	X	X	X	0	1	1	1270	
X	X	X	X	X	0	1	0	900	
X	X	X	X	X	0	0	1	640	
X	X	X	X	X	0	0	0	390	

## Notes

1. X = don't care.
2. The default setting at power-up is 00000000.

## 10.3.39 BEEPER VOLUME CONTROL REGISTER

## 10.3.39.1 Description

This register is used to set the beeper volume. The gain setting is relative to digital full-scale at the input to the Main and Auxiliary channel output DACs. The beeper volume is independent of any other volume setting.

The beeper signal is added to the Main and Auxiliary channel output signals in the  $2 \times f_s$  domain. The beeper volume should be set with great care, when the audio signals in the Main and Auxiliary channels are close to digital full-scale, to avoid output signal distortion due to overload.

## Digital TV Sound Processor (DTVSP)

TDA9875

## 10.3.39.2 Definition

Table 87 Subaddress 44 (note 1)

MSB							LSB		GAIN SETTING (dB)
B7	B6	B5	B4	B3	B2	B1	B0		
X	X	0	0	0	0	0	0	0	
X	X	1	1	1	1	1	1	-3	
X	X	1	1	1	1	1	0	-6	
X	X	1	1	1	1	0	1	-9	
X	X	1	1	1	1	0	0	-12	
X	X	1	1	1	0	1	1	-15	
X	X	1	1	1	0	1	0	-18	
X	X	1	1	1	0	0	1	-21	
X	X	1	1	1	0	0	0	-24	
X	X	1	1	0	1	1	1	-27	
X	X	1	1	0	1	1	0	-30	
X	X	1	1	0	1	0	1	-33	
X	X	1	1	0	1	0	0	-36	
X	X	1	1	0	0	1	1	-39	
X	X	1	1	0	0	1	0	-42	
X	X	1	1	0	0	0	1	-45	
X	X	1	1	0	0	0	0	-48	
X	X	1	0	1	1	1	1	-51	
X	X	1	0	1	1	1	0	-54	
X	X	1	0	1	1	0	1	-57	
X	X	1	0	1	1	0	0	-60	
X	X	1	0	1	0	1	1	-63	
X	X	1	0	1	0	1	0	-66	
X	X	1	0	1	0	0	1	-69	
X	X	1	0	1	0	0	0	-72	
X	X	1	0	0	1	1	1	-75	
X	X	1	0	0	1	1	0	-78	
X	X	1	0	0	1	0	1	-81	
X	X	1	0	0	1	0	0	-84	
X	X	1	0	0	0	1	1	-87	
X	X	1	0	0	0	1	0	-90	
X	X	1	0	0	0	0	1	-93	
X	X	1	0	0	0	0	0	mute (note 2)	

## Notes

1. X = don't care.
2. The default setting at power-up is 00100000.

# Digital TV Sound Processor (DTVSP)

# TDA9875

## 10.3.40 BASS BOOST CONTROL REGISTER

### 10.3.40.1 Description

This register is used to select from a few sample bass boost settings to modify the frequency characteristics of the Main channel (shelving filter). Bits B3 to B0 apply to the left channel, bits B7 to B4 apply to the right channel. This function must be used with care in order to avoid clipping distortion at high volume settings.

More sophisticated control of the bass boost filter can be exercised in the expert mode (see Section 10.5). The user then has full control over this 2nd-order filter and can, within limits, realize bass equalizers with arbitrary centre frequencies, Q factors and boost/cut settings.

### 10.3.40.2 Definition

**Table 88** Subaddress 45 (note 1; see Table 89)

MSB				LSB			
B7	B6	B5	B4	B3	B2	B1	B0

**Note**

1. The default setting at power-up is 00000000.

**Table 89** Gain setting

B7, B3	B6, B2	B5, B1	B4, B0	GAIN SETTING (dB)	CORNER FREQUENCY (Hz)
1	0	1	0	20	350
1	0	0	1	18	350
1	0	0	0	16	350
0	1	1	1	14	350
0	1	1	0	12	350
0	1	0	1	10	350
0	1	0	0	8	350
0	0	1	1	6	350
0	0	1	0	4	350
0	0	0	1	2	350
0	0	0	0	0	350

## Digital TV Sound Processor (DTVSP)

## TDA9875

**10.4 Slave transmitter mode**

As a slave transmitter, the TDA9875 provides 13 registers with status information and data, a part of which is for Philips internal purposes only. These registers can be accessed by means of subaddresses.

**Table 90** General format for reading data from the TDA9875

S	SLAVE ADDRESS	0	ACK	SUBADDRESS	ACK	Sr	SLAVE ADDRESS	1	ACK	DATA	NAm	P
---	---------------	---	-----	------------	-----	----	---------------	---	-----	------	-----	---

**Table 91** Explanation of Tables 90 and 92

BIT	FUNCTION
S	START condition
SLAVE ADDRESS	7-bit device address
0	data direction bit (write to device)
ACK	acknowledge (by the slave)
SUBADDRESS	address of register to read from
Sr	repeated START condition
1	data direction bit (read from device)
DATA	data byte read from register
NAm	not acknowledge (by the master)
Am	acknowledge (by the master)
P	STOP condition

Reading of data can start at any valid subaddress. It is allowed to read more than 1 data byte per transmission from the TDA9875. In this situation, the subaddress is automatically incremented after each data byte, which results in reading the sequence of data bytes from successive register locations, starting at SUBADDRESS.

**Table 92** Format of a transmission using automatic incrementing of subaddresses

S	SLAVE ADDRESS	0	ACK	SUBADDRESS	ACK	Sr	SLAVE ADDRESS	1	ACK	DATA BYTE Am <sup>(1)</sup>	DATA	NAm	P
---	---------------	---	-----	------------	-----	----	---------------	---	-----	--------------------------------	------	-----	---

**Note**

1. n data bytes with auto-increment of subaddresses.

Each data byte in a read sequence, except for the last one, is acknowledged with Am (acknowledge by the master). The subaddresses 'wrap around' from decimal 255 to 0. If an attempt is made to read from a non-existing subaddress, the device will send a data pattern of all ones, i.e. FF in hexadecimal notation.

## Digital TV Sound Processor (DTVSP)

TDA9875

**Table 93** Overview of the slave transmitter registers (note 1)

SUBADDRESS (DECIMAL)	DATA								FUNCTION
	MSB				LSB				
0	s	s	s	s	s	s	s	s	device status (power-on, identification, etc.)
1	s	s	s	s	s	s	s	s	NICAM status
2	e	e	e	e	e	e	e	e	NICAM error count
3	d	d	d	d	d	d	d	d	additional data (LSB)
4	c	c	X	c	c	d	d	d	additional data (MSB)
5	l	l	l	l	l	l	l	l	level read-out (MSB)
6	l	l	l	l	l	l	l	l	level read-out (LSB)
7	X	X	X	c	c	c	c	c	SIF level
251	a	a	a	a	a	a	a	a	test register 3
252	a	a	a	a	a	a	a	a	test register 2
253	a	a	a	a	a	a	a	a	test register 1
254	d	d	d	d	d	d	d	d	device identification code
255	s	s	s	s	s	s	s	s	software identification code

**Note**

1. X indicates a bit that has not yet been assigned to a function. Its meaning is 'don't care', its return value is a zero.

Registers from subaddress 251 to 255 are for Philips internal purposes only. They are considered as a set of registers for the identification of individual members and some key parameters in a family of devices.

A detailed description of the slave transmitter registers is given in below:

## 10.4.1 DEVICE STATUS REGISTER

## 10.4.1.1 Definition

**Table 94** Subaddress 0

BIT	NAME	DESCRIPTION
7 (MSB)	P2IN	input from port 2
6	P1IN	input from port 1
5	RSSF	reserve sound switching flag
4	AMSTAT	auto-mute status
3	VDSP	identification of NICAM sound
2	IDDUA	identification of FM dual sound
1	IDSTE	identification of FM stereo
0 (LSB)	X	don't care

## Digital TV Sound Processor (DTVSP)

TDA9875

## 10.4.1.2 Description

**Table 95** Description of Table 94

NAME	HIGH/LOW	FUNCTION
IDSTE	HIGH	this bit is HIGH if an FM stereo signal has been identified
	LOW	
IDDUA	–	This bit is HIGH if an FM dual-language signal has been identified. When neither IDSTE nor IDDUA are set, the received signal is assumed to be FM mono.
VDSP	HIGH	indicates that digital transmission is a sound source (NICAM)
	LOW	the transmission is either data or currently undefined format (NICAM)
AMSTAT	–	if this bit is HIGH, it indicates that the auto-muting function has switched from NICAM to the program of the first sound carrier (i.e. FM mono or AM in NICAM L systems)
RSSF	HIGH	This bit is a copy of the C4 bit in the NICAM status register. It indicates that the FM (or AM for standard L) sound matches the digital transmission and auto-muting should be enabled.
	LOW	auto-muting should be disabled, as analog and digital sound are different
P1IN, P2IN	–	these bits reflect the status of the corresponding general purpose port pins, see Section 10.3.2

## 10.4.2 NICAM STATUS REGISTER

## 10.4.2.1 Definition

**Table 96** Subaddress 1

BIT	NAME	DESCRIPTION
7 (MSB)	C4	NICAM application control bits
6	C3	
5	C2	
4	C1	
3	OSB	synchronization bit
2	CFC	configuration change
1	S/MB	identification of NICAM stereo
0 (LSB)	D/SB	identification of NICAM dual mono

## Digital TV Sound Processor (DTVSP)

TDA9875

## 10.4.2.2 Description

**Table 97** Description of Table 96

NAME	HIGH/LOW	FUNCTION
D/SB	HIGH	if this bit is HIGH it indicates dual mono mode
	LOW	
S/MB	HIGH	if this bit is HIGH it indicates stereo mode
	LOW	
CFC	HIGH	if this bit is HIGH, it indicates a configuration change at the 16 frame (C0) boundary
	LOW	
OSB	HIGH	indicates that the device has both frame and C0 (16 frame) synchronization
	LOW	the audio output from the NICAM part should be digital silence
C1, C2, C3, C4	HIGH	these bits correspond to the control bits C1 to C4 in the NICAM transmission
	LOW	

## 10.4.2.3 Notes

The TDA9875 does not support the Extended Control Modes. Therefore, the program of the first sound carrier (i.e. FM mono or AM) is selected for reproduction in case bit C3 is set HIGH, independent of bit AMUTE in the NICAM configuration register being set or not.

When a NICAM transmitter is switched off, the device will lose synchronization. In this situation the program of the first sound carrier is selected for reproduction, independent of bit AMUTE being set or not.

## 10.4.3 NICAM ERROR COUNT REGISTER

## 10.4.3.1 Description

Bits B7 to B0 contain the number of errors occurring in the previous 128 ms period. The register is updated every 128 ms.

## 10.4.3.2 Definition

**Table 98** Subaddress 2

MSB							LSB
B7	B6	B5	B4	B3	B2	B1	B0

## Digital TV Sound Processor (DTVSP)

TDA9875

## 10.4.4 ADDITIONAL DATA REGISTERS

## 10.4.4.1 Description

These two bytes provide information on the additional data bits. ADBYTE0 is stored at subaddress 3.

## 10.4.4.2 Definition

**Table 99** Subaddress 3

BIT	NAME
7 (MSB)	AD7
6	AD6
5	AD5
4	AD4
3	AD3
2	AD2
1	AD1
0 (LSB)	AD0

**Table 100** Subaddress 4

BIT	NAME
7 (MSB)	OVW
6	SAD
5	X (don't care)
4	CI1
3	CI2
2	AD10
1	AD9
0 (LSB)	AD8

**Table 101** Description of Tables 99 and 100

NAME	HIGH/LOW	FUNCTION
AD10 to AD0	–	comprise the additional data word
CI1, CI2	–	these are CI bits decoded by majority logic from the parity checks of the last ten samples in a frame
SAD	HIGH	new additional data is written into the IC
	LOW	reset, when the additional data bits are read
OVW	–	if this bit is HIGH, new additional data bits are written to the IC without the previous bits being read



# Digital TV Sound Processor (DTVSP)

# TDA9875

## 10.4.5 LEVEL READ-OUT REGISTERS

### 10.4.5.1 Description

These two bytes constitute a word that provides data from a location that has been specified with the monitor select register. The most significant byte of the data is stored at subaddress 5.

If peak-level monitoring has been selected, the peak-level monitoring register is cleared and monitoring resumes after its contents has been transferred to these two bytes.

### 10.4.5.2 Definition

**Table 102** Subaddress 5

BIT
7 (most significant bit or sign bit)
6
5
4
3
2
1
0

**Table 103** Subaddress 6

BIT
7
6
5
4
3
2
1
0 (least significant bit)

## 10.4.6 SIF LEVEL REGISTER

### 10.4.6.1 Description

When the SIF AGC is on, bits B4 to B0 of this register contain a number that gives an indication of the SIF input level. That number can be interpreted in the same way as the AGC gain register setting (see Section 10.3, subaddress 0), i.e., if the SIF AGC were set to a fixed gain and the same number loaded into the AGC gain register, the current SIF input signal level would generate an SIF ADC output close to full-scale.

When the SIF AGC is off, this register returns the contents of the AGC gain register.

### 10.4.6.2 Definition

**Table 104** Subaddress 7 (note 1)

MSB							LSB
B7	B6	B5	B4	B3	B2	B1	B0

### Note

- Bits B5, B6 and B7 are don't care.

## 10.4.7 TEST REGISTER 3

### 10.4.7.1 Description

This register contains, as a binary number, the highest memory address used for the Coefficient RAM (CRAM, expert mode).

The first version will have the identification 01111111.

### 10.4.7.2 Definition

**Table 105** Subaddress 251

MSB							LSB
B7	B6	B5	B4	B3	B2	B1	B0

## 10.4.8 TEST REGISTER 2

### 10.4.8.1 Description

This register contains, as a binary number, the highest subaddress used for slave receiver registers.

The first version will have the identification 00101101.

### 10.4.8.2 Definition

**Table 106** Subaddress 252

MSB							LSB
B7	B6	B5	B4	B3	B2	B1	B0

## 10.4.9 TEST REGISTER 1

### 10.4.9.1 Description

This register contains, as a binary number, the highest subaddress used for slave transmitter (status) registers.

The first version will have the identification 00000111.

# Digital TV Sound Processor (DTVSP)

# TDA9875

### 10.4.9.2 Definition

**Table 107** Subaddress 253

<b>MSB</b>							<b>LSB</b>
B7	B6	B5	B4	B3	B2	B1	B0

### 10.4.10 DEVICE IDENTIFICATION CODE

#### 10.4.10.1 Description

There will be several devices in the digital TV sound processor family, with TDA9875 being the first member. This byte is used to identify the individual family members purely for Philips internal use.

The first version will have the identification 00000000.

#### 10.4.10.2 Definition

**Table 108** Subaddress 254

<b>MSB</b>							<b>LSB</b>
B7	B6	B5	B4	B3	B2	B1	B0

### 10.4.11 SOFTWARE IDENTIFICATION CODE

#### 10.4.11.1 Description

It is likely that during the life time of this family of devices several versions of the DSP software will be made, e.g., to accommodate new application concepts, respond to customer wishes, etc. This byte is used to identify the different releases purely for Philips internal use.

The first version will have the identification 00000000.

### 10.4.11.2 Definition

**Table 109** Subaddress 255

<b>MSB</b>							<b>LSB</b>
B7	B6	B5	B4	B3	B2	B1	B0

## 10.5 Expert mode

In addition to the slave receiver and slave transmitter modes previously described, there is a special 'expert' mode that gives direct write access to the internal CRAM of the DSP.

In this mode, transferred data contain 12-bit-wide coefficients. As those coefficients bypass on-chip coefficient look-up tables for many functions, they directly influence the processing of signals within the DSP.

This mode must be used with great care. It can be used to create user-defined characteristics, such as a tone control with different corner frequencies or special boost/cut characteristics to correct the low-frequency loudspeaker and/or cabinet frequency responses.

**Table 110** General format for entering the expert mode and writing coefficients into the TDA9875

S	SLAVE ADDRESS	0	ACK	10000000	ACK	CRAM ADDRESS	ACK	DATA	ACK	DATA	ACK	P
---	---------------	---	-----	----------	-----	--------------	-----	------	-----	------	-----	---

**Table 111** Explanation of Table 110

<b>BIT</b>	<b>FUNCTION</b>
S	START condition
SLAVE ADDRESS	7-bit device address
0	data direction bit (write to device)
ACK	acknowledge
10000000	pattern to enter the expert mode
CRAM ADDRESS	start address of coefficient RAM to write to
DATA	data byte containing part of a coefficient
P	STOP condition

## Digital TV Sound Processor (DTVSP)

## TDA9875

As the coefficients do not fit into one data byte, they have to be split and arranged (see Table 112). The most significant bit is transferred first.

**Table 112** General format (notes 1, 2 and 3)

BYTE	DATA								DESCRIPTION
1. data byte	a	a	a	a	a	a	a	a	2 MST of 1st coefficient
2. data byte	a	a	a	a	X	X	X	X	1 LST of 1st coefficient

#### Notes

1. X = don't care.
2. MST = most significant third.
3. LST = least significant third.

The general format described in Table 112 shows the minimum number of data bytes required, i.e. two bytes for the transfer of a single coefficient.

Should more than one coefficient be sent, then the CRAM address will be automatically incremented after each coefficient, resulting in writing the sequence of coefficients into successive memory locations, starting at CRAM ADDRESS. A transmission can start with any valid CRAM address. If two coefficients are to be transferred, they are arranged as shown in Table 113.

**Table 113** Transfer of two coefficients

BYTE	DATA								DESCRIPTION
1 data byte	a	a	a	a	a	a	a	a	2 MST of 1st coefficient
2 data byte	a	a	a	a	b	b	b	b	1 LST of 1st coefficient + 1 MST of 2nd coefficient
3 data byte	b	b	b	b	b	b	b	b	2 LST of 2nd coefficient

With any odd number of coefficients to be transferred, the least significant nibble of the last byte is regarded as containing don't care data.

As the transfer of coefficients cannot be accomplished within one audio sample period, it is necessary that received coefficients be buffered and made active all at the same time to avoid audio signal transients. The receive buffer is designed to store up to 8 coefficients in addition to the CRAM address. Each byte that fits into the buffer is acknowledged with ACK (acknowledge). If an attempt is made to write more coefficients than the buffer can store, the device acknowledges with NACK (not acknowledge) and any further coefficients are ignored. Coefficients that are already in the receive buffer remain intact.

An expert mode transfers ends when the I<sup>2</sup>C-bus STOP condition or a repeated START condition has been detected. Only those coefficients that have been received during the last transmission will then be copied from the buffer to the CRAM.

To make efficient and correct use of the expert mode, it is recommended to transfer all coefficients for any one function in a single transmission.

There is no checking of memory addresses and the automatic incrementing of addresses does not stop at the highest used CRAM address. The user of this expert mode must be fully acquainted with the relevant procedures.

More information concerning the functions of this device, such as filter structures, the number of coefficients per function, their default values, memory addresses, etc., can be supplied on request at a later date.

## 11 I<sup>2</sup>S-BUS DESCRIPTION

The feature interface of the TDA9875 contains two serial audio inputs and outputs and associated clock signals. It can be used to supply, for example, audio signals from received TV programs to a digital audio output device (AES/EBU format), or import serial audio signals from other sources for reproduction through the TV set's

## Digital TV Sound Processor (DTVSP)

## TDA9875

loudspeaker and/or headphone channels. Apart from such simple data input or output, it is also possible to run audio signals through an external DSP, which performs some additional functions, such as room simulation, Dolby Surround Pro Logic etc. and feed those signals back into the loudspeaker and/or headphone channels of the TDA9875.

Two serial audio formats are supported at the feature interface, i.e. the I<sup>2</sup>S-bus format and a very similar MSB-aligned format. The difference is illustrated in Fig.7.

In both formats the left audio channel of a stereo sample pair is output first and is placed on the serial data line (SDI for input, SDO for output) when the word select line (WS) is LOW. Data is written at the trailing edge of SCK and read at the leading edge of SCK. The most significant bit is sent first.

At power-up, the outputs of the feature interface are 3-stated to reduce EMC and allow for combinations with other ICs. If output is desired, it has to be activated by means of an I<sup>2</sup>C-bus command.

When the output is enabled, the serial audio data can be taken from pins SDO1 and SDO2. Depending on the signal source, switch and matrix positions, the output can be either mono, stereo or dual language sound on either output.

The word select output is clocked with the audio sample frequency at 32 kHz. The serial clock output (SCK) is clocked at a frequency of 2.048 MHz. This means, that there are 64 clock pulses per pair of stereo output samples, or 32 clock pulses per sample. Depending again on the signal source, the number of significant bits on the serial data outputs, SDO1 and SDO2, is between 14 and 18.

Apart from just feeding a digital audio device, such as a DAC or an AES/EBU transmitter, the serial data outputs can be connected directly to the serial inputs (loop-back connection) or first to an external device, e.g. a feature DSP such as the SAA7710 and then back to the serial inputs. In all of these configurations, the SCK and WS clocks will be generated by the TDA9875, which then is the I<sup>2</sup>S-bus master.

The serial data inputs, SDI1 and SDI2, are active at all times, independent of the serial data outputs being on or off.

When the serial data outputs are off (either after power-up or via the appropriate I<sup>2</sup>C-bus command) serial data and clocks WS and SCK from a separate digital audio source can be fed into the TDA9875, be processed and output in accordance with internal selector positions, provided that the following criteria are met:

- 32 kHz audio sample frequency
- 32 clock bits per sample
- External timing and data synchronized to TDA9875.

In such cases, the external source is the I<sup>2</sup>S-bus master and the TDA9875 is the I<sup>2</sup>S-bus slave.

To support synchronization of external devices or as a master clock for them, a symmetrical system clock output, SYSCLK, is available from the TDA9875. At power-up it is off. It can be enabled and the output frequency set via an I<sup>2</sup>C-bus command. Available output frequencies are 8.192, 12.288, 16.384 and 24.576 MHz.

Digital TV Sound Processor (DTVSP)

TDA9875

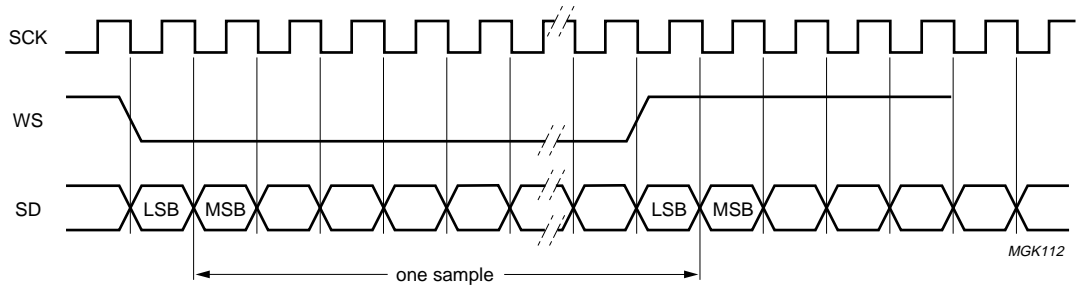

a. I<sup>2</sup>S-bus format.

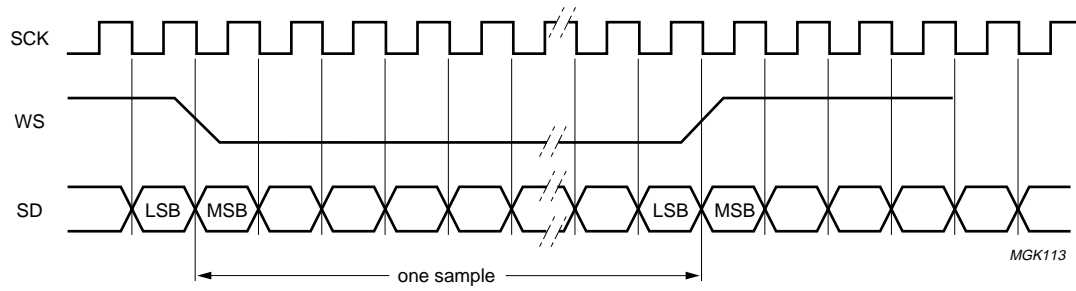

b. MSB-aligned format.

Fig.7 Serial audio interface formats.

# Digital TV Sound Processor (DTVSP)

# TDA9875

## 12 EXTERNAL COMPONENTS

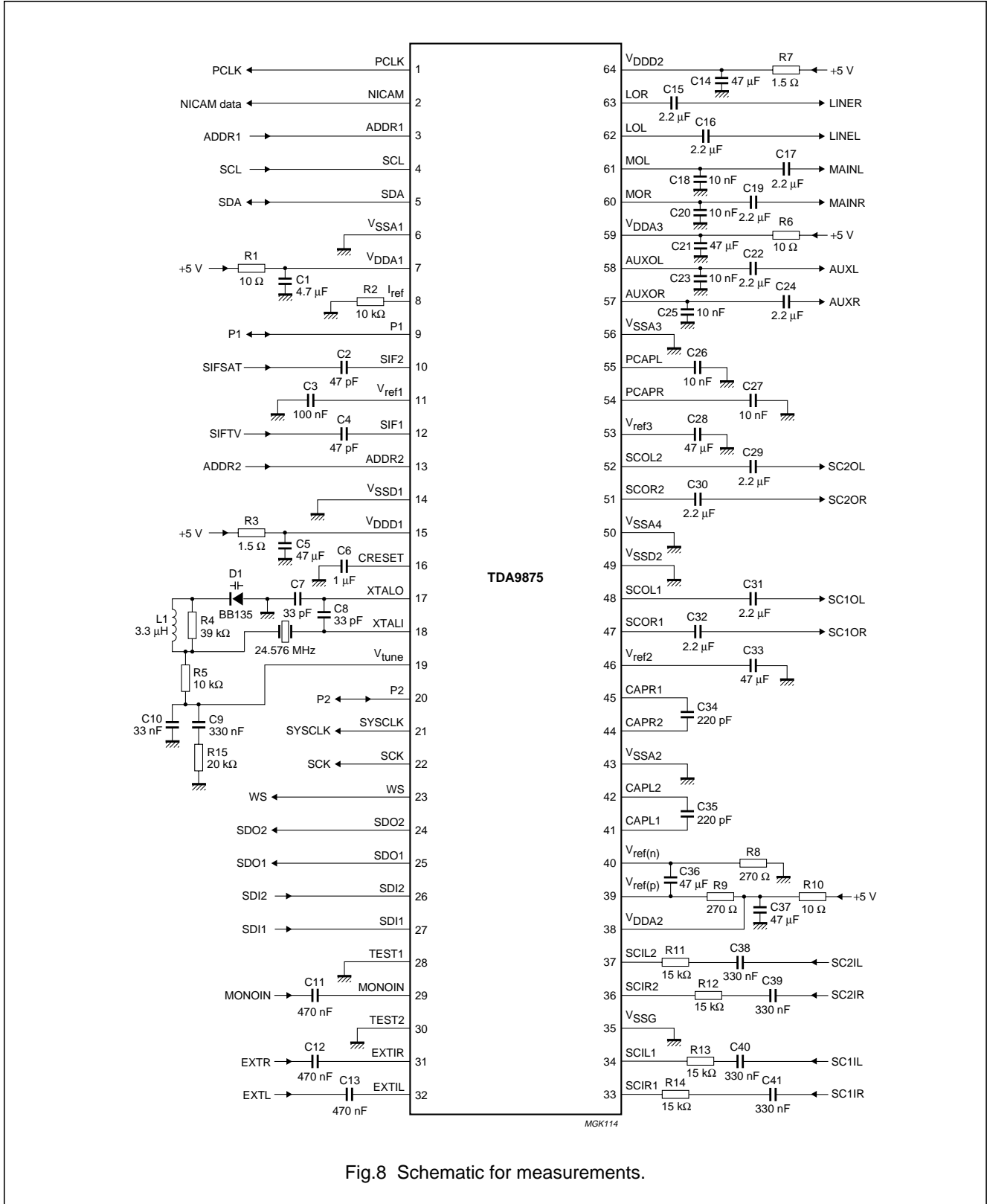

Fig.8 Schematic for measurements.

Digital TV Sound Processor (DTVSP)

TDA9875

13 PACKAGE OUTLINE

SDIP64: plastic shrink dual in-line package; 64 leads (750 mil)

SOT274-1

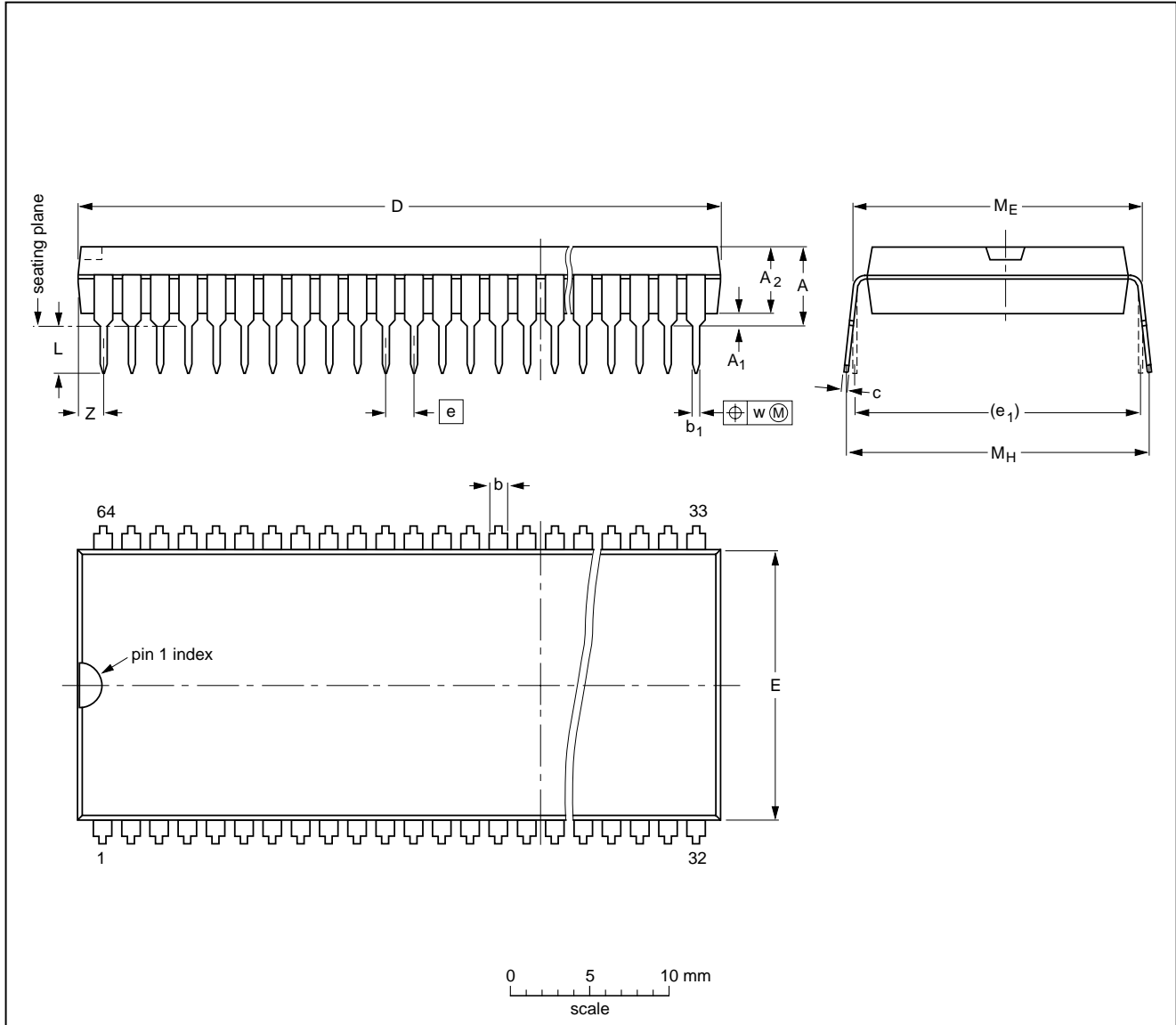

DIMENSIONS (mm are the original dimensions)

UNIT	A max.	A <sub>1</sub> min.	A <sub>2</sub> max.	b	b <sub>1</sub>	c	D <sup>(1)</sup>	E <sup>(1)</sup>	e	e <sub>1</sub>	L	M <sub>E</sub>	M <sub>H</sub>	w	z <sup>(1)</sup> max.
mm	5.84	0.51	4.57	1.3 0.8	0.53 0.40	0.32 0.23	58.67 57.70	17.2 16.9	1.778	19.05	3.2 2.8	19.61 19.05	20.96 19.71	0.18	1.73

Note

1. Plastic or metal protrusions of 0.25 mm maximum per side are not included.

OUTLINE VERSION	REFERENCES				EUROPEAN PROJECTION	ISSUE DATE
	IEC	JEDEC	EIAJ			
SOT274-1						92-10-13 95-02-04

## Digital TV Sound Processor (DTVSP)

TDA9875

**14 SOLDERING****14.1 Introduction**

There is no soldering method that is ideal for all IC packages. Wave soldering is often preferred when through-hole and surface mounted components are mixed on one printed-circuit board. However, wave soldering is not always suitable for surface mounted ICs, or for printed-circuits with high population densities. In these situations reflow soldering is often used.

This text gives a very brief insight to a complex technology. A more in-depth account of soldering ICs can be found in our "IC Package Databook" (order code 9398 652 90011).

**14.2 Soldering by dipping or by wave**

The maximum permissible temperature of the solder is 260 °C; solder at this temperature must not be in contact

with the joint for more than 5 seconds. The total contact time of successive solder waves must not exceed 5 seconds.

The device may be mounted up to the seating plane, but the temperature of the plastic body must not exceed the specified maximum storage temperature ( $T_{stg\ max}$ ). If the printed-circuit board has been pre-heated, forced cooling may be necessary immediately after soldering to keep the temperature within the permissible limit.

**14.3 Repairing soldered joints**

Apply a low voltage soldering iron (less than 24 V) to the lead(s) of the package, below the seating plane or not more than 2 mm above it. If the temperature of the soldering iron bit is less than 300 °C it may remain in contact for up to 10 seconds. If the bit temperature is between 300 and 400 °C, contact may be up to 5 seconds.

**15 DEFINITIONS**

<b>Data sheet status</b>	
Objective specification	This data sheet contains target or goal specifications for product development.
Preliminary specification	This data sheet contains preliminary data; supplementary data may be published later.
Product specification	This data sheet contains final product specifications.
<b>Limiting values</b>	
Limiting values given are in accordance with the Absolute Maximum Rating System (IEC 134). Stress above one or more of the limiting values may cause permanent damage to the device. These are stress ratings only and operation of the device at these or at any other conditions above those given in the Characteristics sections of the specification is not implied. Exposure to limiting values for extended periods may affect device reliability.	
<b>Application information</b>	
Where application information is given, it is advisory and does not form part of the specification.	

**16 LIFE SUPPORT APPLICATIONS**

These products are not designed for use in life support appliances, devices, or systems where malfunction of these products can reasonably be expected to result in personal injury. Philips customers using or selling these products for use in such applications do so at their own risk and agree to fully indemnify Philips for any damages resulting from such improper use or sale.

**17 PURCHASE OF PHILIPS I<sup>2</sup>C COMPONENTS**

Purchase of Philips I<sup>2</sup>C components conveys a license under the Philips' I<sup>2</sup>C patent to use the components in the I<sup>2</sup>C system provided the system conforms to the I<sup>2</sup>C specification defined by Philips. This specification can be ordered using the code 9398 393 40011.



Digital TV Sound Processor (DTVSP)

TDA9875

---

**NOTES**

Digital TV Sound Processor (DTVSP)

TDA9875

---

**NOTES**

Digital TV Sound Processor (DTVSP)

TDA9875

---

**NOTES**

# Philips Semiconductors – a worldwide company

**Argentina:** see South America

**Australia:** 34 Waterloo Road, NORTH RYDE, NSW 2113,  
Tel. +61 2 9805 4455, Fax. +61 2 9805 4466

**Austria:** Computerstr. 6, A-1101 WIEN, P.O. Box 213, Tel. +43 160 1010,  
Fax. +43 160 101 1210

**Belarus:** Hotel Minsk Business Center, Bld. 3, r. 1211, Volodarski Str. 6,  
220050 MINSK, Tel. +375 172 200 733, Fax. +375 172 200 773

**Belgium:** see The Netherlands

**Brazil:** see South America

**Bulgaria:** Philips Bulgaria Ltd., Energoproject, 15th floor,  
51 James Bourchier Blvd., 1407 SOFIA,  
Tel. +359 2 689 211, Fax. +359 2 689 102

**Canada:** PHILIPS SEMICONDUCTORS/COMPONENTS,  
Tel. +1 800 234 7381

**China/Hong Kong:** 501 Hong Kong Industrial Technology Centre,  
72 Tat Chee Avenue, Kowloon Tong, HONG KONG,  
Tel. +852 2319 7888, Fax. +852 2319 7700

**Colombia:** see South America

**Czech Republic:** see Austria

**Denmark:** Prags Boulevard 80, PB 1919, DK-2300 COPENHAGEN S,  
Tel. +45 32 88 2636, Fax. +45 31 57 0044

**Finland:** Sinikalliontie 3, FIN-02630 ESPOO,  
Tel. +358 9 615800, Fax. +358 9 61580920

**France:** 51 Rue Carnot, BP317, 92156 SURESNES Cedex,  
Tel. +33 1 40 99 6161, Fax. +33 1 40 99 6427

**Germany:** Hammerbrookstraße 69, D-20097 HAMBURG,  
Tel. +49 40 23 53 60, Fax. +49 40 23 536 300

**Greece:** No. 15, 25th March Street, GR 17778 TAVROS/ATHENS,  
Tel. +30 1 4894 339/239, Fax. +30 1 4814 240

**Hungary:** see Austria

**India:** Philips INDIA Ltd, Band Box Building, 2nd floor,  
254-D, Dr. Annie Besant Road, Worli, MUMBAI 400 025,  
Tel. +91 22 493 8541, Fax. +91 22 493 0966

**Indonesia:** see Singapore

**Ireland:** Newstead, Clonskeagh, DUBLIN 14,  
Tel. +353 1 7640 000, Fax. +353 1 7640 200

**Israel:** RAPAC Electronics, 7 Kehilat Saloniki St, PO Box 18053,  
TEL AVIV 61180, Tel. +972 3 645 0444, Fax. +972 3 649 1007

**Italy:** PHILIPS SEMICONDUCTORS, Piazza IV Novembre 3,  
20124 MILANO, Tel. +39 2 6752 2531, Fax. +39 2 6752 2557

**Japan:** Philips Bldg 13-37, Kohnan 2-chome, Minato-ku, TOKYO 108,  
Tel. +81 3 3740 5130, Fax. +81 3 3740 5077

**Korea:** Philips House, 260-199 Itaewon-dong, Yongsan-ku, SEOUL,  
Tel. +82 2 709 1412, Fax. +82 2 709 1415

**Malaysia:** No. 76 Jalan Universiti, 46200 PETALING JAYA, SELANGOR,  
Tel. +60 3 750 5214, Fax. +60 3 757 4880

**Mexico:** 5900 Gateway East, Suite 200, EL PASO, TEXAS 79905,  
Tel. +9-5 800 234 7381

**Middle East:** see Italy

**Netherlands:** Postbus 90050, 5600 PB EINDHOVEN, Bldg. VB,  
Tel. +31 40 27 82785, Fax. +31 40 27 88399

**New Zealand:** 2 Wagener Place, C.P.O. Box 1041, AUCKLAND,  
Tel. +64 9 849 4160, Fax. +64 9 849 7811

**Norway:** Box 1, Manglerud 0612, OSLO,  
Tel. +47 22 74 8000, Fax. +47 22 74 8341

**Philippines:** Philips Semiconductors Philippines Inc.,  
106 Valero St. Salcedo Village, P.O. Box 2108 MCC, MAKATI,  
Metro MANILA, Tel. +63 2 816 6380, Fax. +63 2 817 3474

**Poland:** Ul. Lukiska 10, PL 04-123 WARSZAWA,  
Tel. +48 22 612 2831, Fax. +48 22 612 2327

**Portugal:** see Spain

**Romania:** see Italy

**Russia:** Philips Russia, Ul. Usatcheva 35A, 119048 MOSCOW,  
Tel. +7 095 755 6918, Fax. +7 095 755 6919

**Singapore:** Lorong 1, Toa Payoh, SINGAPORE 1231,  
Tel. +65 350 2538, Fax. +65 251 6500

**Slovakia:** see Austria

**Slovenia:** see Italy

**South Africa:** S.A. PHILIPS Pty Ltd., 195-215 Main Road Martindale,  
2092 JOHANNESBURG, P.O. Box 7430 Johannesburg 2000,  
Tel. +27 11 470 5911, Fax. +27 11 470 5494

**South America:** Al. Vicente Pinzon, 173, 6th floor,  
04547-130 SÃO PAULO, SP, Brazil,  
Tel. +55 11 821 2333, Fax. +55 11 821 2382

**Spain:** Balmes 22, 08007 BARCELONA,  
Tel. +34 3 301 6312, Fax. +34 3 301 4107

**Sweden:** Kottbygatan 7, Akalla, S-16485 STOCKHOLM,  
Tel. +46 8 632 2000, Fax. +46 8 632 2745

**Switzerland:** Allmendstrasse 140, CH-8027 ZÜRICH,  
Tel. +41 1 488 2686, Fax. +41 1 488 3263

**Taiwan:** Philips Semiconductors, 6F, No. 96, Chien Kuo N. Rd., Sec. 1,  
TAIPEI, Taiwan Tel. +886 2 2134 2865, Fax. +886 2 2134 2874

**Thailand:** PHILIPS ELECTRONICS (THAILAND) Ltd.,  
209/2 Sanpavuth-Bangna Road Prakanong, BANGKOK 10260,  
Tel. +66 2 745 4090, Fax. +66 2 398 0793

**Turkey:** Talatpasa Cad. No. 5, 80640 GÜLTEPE/ISTANBUL,  
Tel. +90 212 279 2770, Fax. +90 212 282 6707

**Ukraine:** PHILIPS UKRAINE, 4 Patrice Lumumba str., Building B, Floor 7,  
252042 KIEV, Tel. +380 44 264 2776, Fax. +380 44 268 0461

**United Kingdom:** Philips Semiconductors Ltd., 276 Bath Road, Hayes,  
MIDDLESEX UB3 5BX, Tel. +44 181 730 5000, Fax. +44 181 754 8421

**United States:** 811 East Arques Avenue, SUNNYVALE, CA 94088-3409,  
Tel. +1 800 234 7381

**Uruguay:** see South America

**Vietnam:** see Singapore

**Yugoslavia:** PHILIPS, Trg N. Pasica 5/v, 11000 BEOGRAD,  
Tel. +381 11 625 344, Fax. +381 11 635 777

**For all other countries apply to:** Philips Semiconductors,  
International Marketing & Sales Communications, Building BE-p, P.O. Box 218,  
5600 MD EINDHOVEN, The Netherlands, Fax. +31 40 27 24825

**Internet:** <http://www.semiconductors.philips.com>

© Philips Electronics N.V. 1998

SCA57

All rights are reserved. Reproduction in whole or in part is prohibited without the prior written consent of the copyright owner.

The information presented in this document does not form part of any quotation or contract, is believed to be accurate and reliable and may be changed without notice. No liability will be accepted by the publisher for any consequence of its use. Publication thereof does not convey nor imply any license under patent- or other industrial or intellectual property rights.

Printed in The Netherlands

545104/1200/02/pp92

Date of release: 1998 Feb 13

Document order number: 9397 750 03003

*Let's make things better.*

**Philips  
Semiconductors**



**PHILIPS**